

**Royal College**  
Annual Report and Accounts  
2010

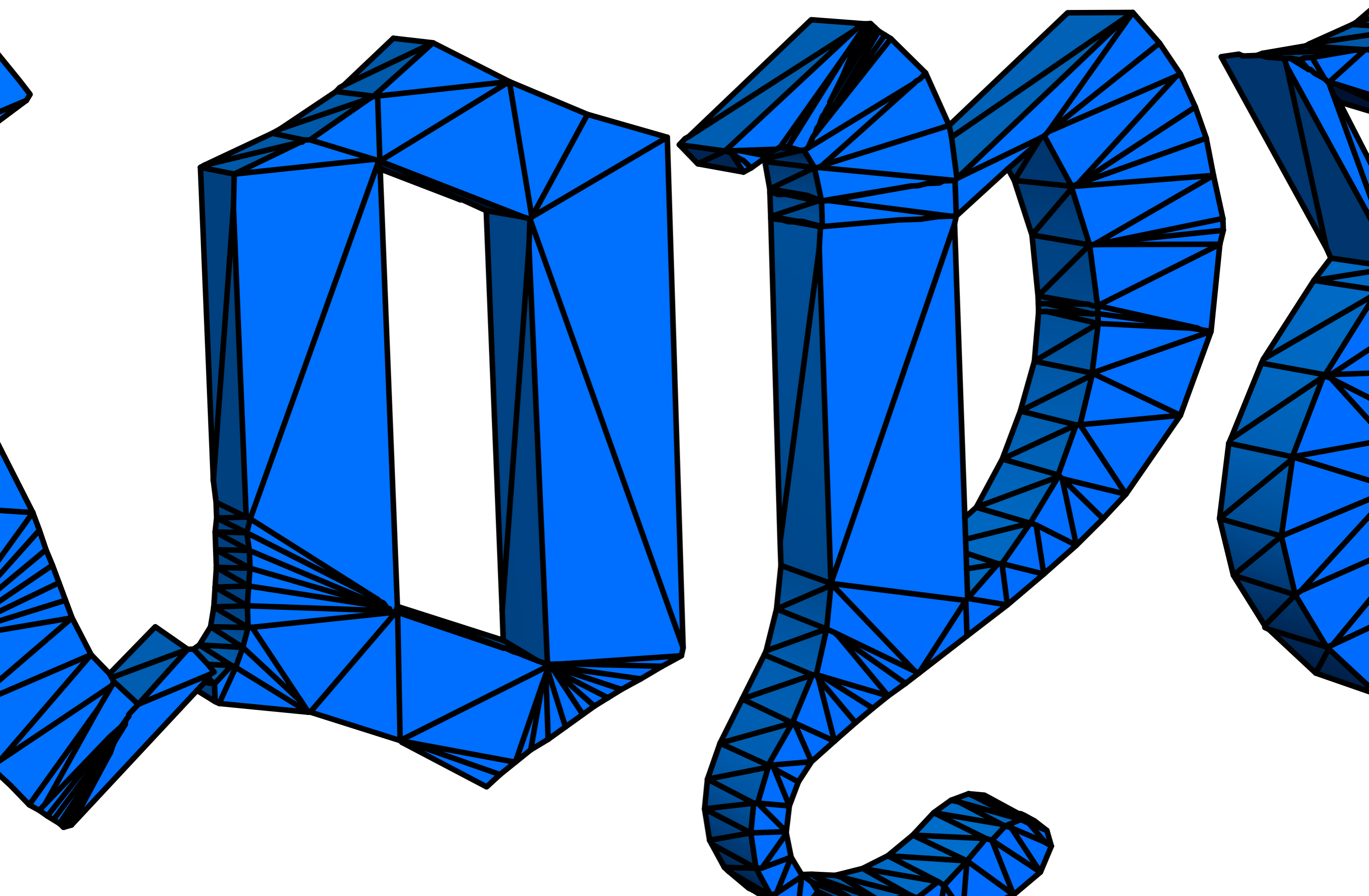

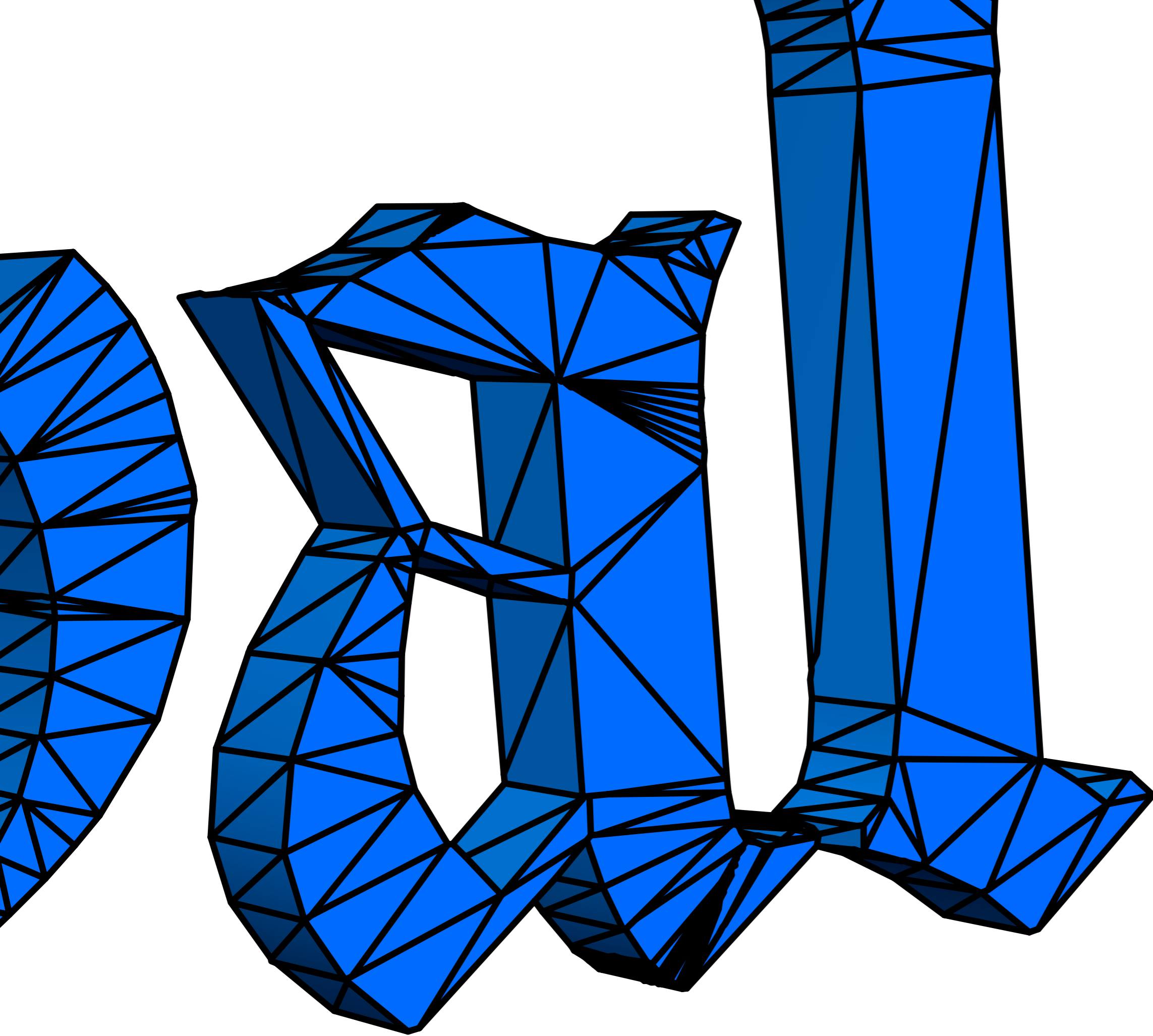

**Annual Report and Accounts 2010 - Royal College**

Copyright © 2010-2011 Royal College, Colombo, Sri Lanka.

All rights reserved. No part of this book may be reproduced, stored in a retrieval system or transmitted in any form or by any means, without the prior written permission of the publisher, except in the case of brief quotations embedded in critical articles or reviews.

Compiled by Hisham Doole, Kumuditha Udugama  
Design and concept by Pathum Egodawatta  
Photographs by Darshana Kuruppu

Published by  
**Royal College, Colombo 07.**  
[www.royalcollege.lk](http://www.royalcollege.lk)



**Royal College**  
Annual Report and Accounts  
2010



# Contents

Mission and Vision	10
School Officers	11
Message from the Principal	12
Administration	13
College Crest	14
College Song	15
History	20
Statistics	26
Infrastructure	36
Results Analysis	
Advanced Level Examination 2010	56
Ordinary Level Examination 2010	67
National and International Achievements	70
Achievements in Sports and Games	80
Activities of Clubs and Societies	88
Religious and Cultural Activities	102
Community Service Projects	106
Development Projects	112
Projects by School Development Society	116
Accounts	124

# Vision and Mission

## Vision

“Nurture Sri Lankan youth to be wholesome citizens and empower them to be globally competitive”

## Mission

### 1. Teaching, Learning and Assessment

- a. Recognize teaching 21st century skills as a vital component to nurture students to become globally competitive, make teaching skills as an integral part of the curriculum for all subjects with effective assessment methods in place to monitor progress.
- b. Empower teachers to use novel methods and technology to facilitate students learning the government curriculum in a more engaging, inspiring and a collaborative manner.
- c. Implement ICT as an integral component of teaching, learning and assessment with relevant ICT tools and facilities made available for use by teachers and students as and when required.

### 2. Professional Development

- a. Implement an effective professional development and performance monitoring strategies to ensure all staff meets both government and school standards.
- b. Ensure Teachers and students practice peer coaching and mentoring and the ICT used extensively for this purpose.
- c. Implement well developed, engaging and effective training programs on the use of ICT in the government curriculum in an innovative and creative manner.

### 3. Learning Environment

- a. ICT enabled learning spaces supporting a range of teaching and learning styles that encourage personalized and student centered approaches to learning.
- b. Modern ICT based on-line collaborative tools to facilitate learning beyond classrooms for students.
- c. Modern ICT facilities to create virtual learning environments with access to other stakeholders for progress monitoring.

### 4. Leadership and Culture of Innovation

- a. Implement strategies to encourage innovation and creativity across the school system with effective methods to reward and recognize stakeholders and to collaborate and share best practices both locally and globally.
- b. Facilitate leadership development across the school at all levels by encouraging innovation and creativity in all areas including co-curricular activities and administrative processes using global best practices coupled with effective monitoring methods.
- c. Implement effective strategies to engage and exploit stakeholders and wider learning community for school development.

### 5. Personality and Values

- a. Implement strategies to cultivate, uphold, demonstrate and recognize religious and cultural values across the multi-ethnic and multi-religious Royal community.
- b. Implement strategies to facilitate and inspire students to take part in co-curricular activities to develop young boys to vibrant personalities.

# School Officers

Principal

H.A.U. Gunaskara

Senior Deputy Principal

G. D. S. Keerthisena

Deputy Principals

M. Kanapathipillei (Tamil Medium)  
C. L. Attygalle (Primary Section)  
L. L. B. Tennakoon (Upper Middle Section)  
J. Sumedha Jayawaeera (Middle Section)

Assistant Principals

B.P.R. Perera  
Y.M. Jayasuriya  
S. Illeperuma  
A. L. Rozairo  
H. Jayawardhana

# Message from the Principal

Year 2010 was very special to Royal College. Established in 1835, Royal College celebrated its 175<sup>th</sup> anniversary in the year 2010 with series of commemorative events held throughout the year. We continued to produce best results at both the GCE A/L and O/L examinations held during the year and recorded many achievements in the co-curricular area which included sports and other social activities. We managed to secure few special achievements during this period. Royal College was crowned as one of the world's best innovative schools in the Microsoft Innovative Schools program in the year 2009 and we successfully took part in the National ICT Excellence Award competition organized by the Ministry of Education during this period.

We achieved significant progress in all areas be it Academic Development, Innovation Culture, Leadership Development, Learning Community, Strategic Development Planning and Innovative use of ICT during the year. We had to face lot of challenges during the year both in academic and non-academic spheres. School Development Society lived up to the expectations and managed to conquer almost all challenges faced and to achieve desired objectives.

Royal College adopted various novel approaches in pursuit of our Vision and Mission towards achieving excellence in what we offer to our students in line with the global needs of the 21<sup>st</sup> Century. Being the largest and most respected education institution in the country, we have placed more emphasis in using Information and Communication Technology (ICT) to complement teaching and learning activities of the school.

The Honorable Minister of Education Bandula Gunawardena unveiled 21<sup>st</sup> Century Teacher and Virtual School projects, which were the latest ICT innovations at Royal College in the year 2010. These unique ICT initiatives at Royal College were initiated for the benefit of students and teachers. We believe these concepts would be of immense value for all other schools in the country not only the Royal College.

School Development Society (SDS) played the pivotal role in facilitating success in both academic and non-academic fields. They had to face multi-faceted challenges in assisting the school administration by managing school finances, ensuring regulatory compliance and most importantly facilitating tasks which seemed impossible to any other.

Annual Report of the Royal College School Development Society contains details of contributions made towards achieving success at Royal College during the year 2010. It is not possible to include all the effort spent by the able members of the committee in this report and therefore it is my duty to appreciate the contribution of all members towards achieving the desired objectives during the year. It was a tremendous task for the SDS to live up to the challenges during the year and they have demonstrated their capabilities beyond any doubts. I wish to express my sincere thanks to all the members of the SDS executive committee and other sub committees for a job well done. Further I wish to extend my sincere thanks to all stakeholders of Royal College who helped us in numerous ways in our journey towards achieving excellence.

Last but not least I wish to take this opportunity to thank the SDS office bearers and other staff for their efforts spent in carrying out SDS activities in compliance with regulations which enabled us to produce this annual report without any difficulty.

  
Upali Gunasekara  
Principal

## Administration

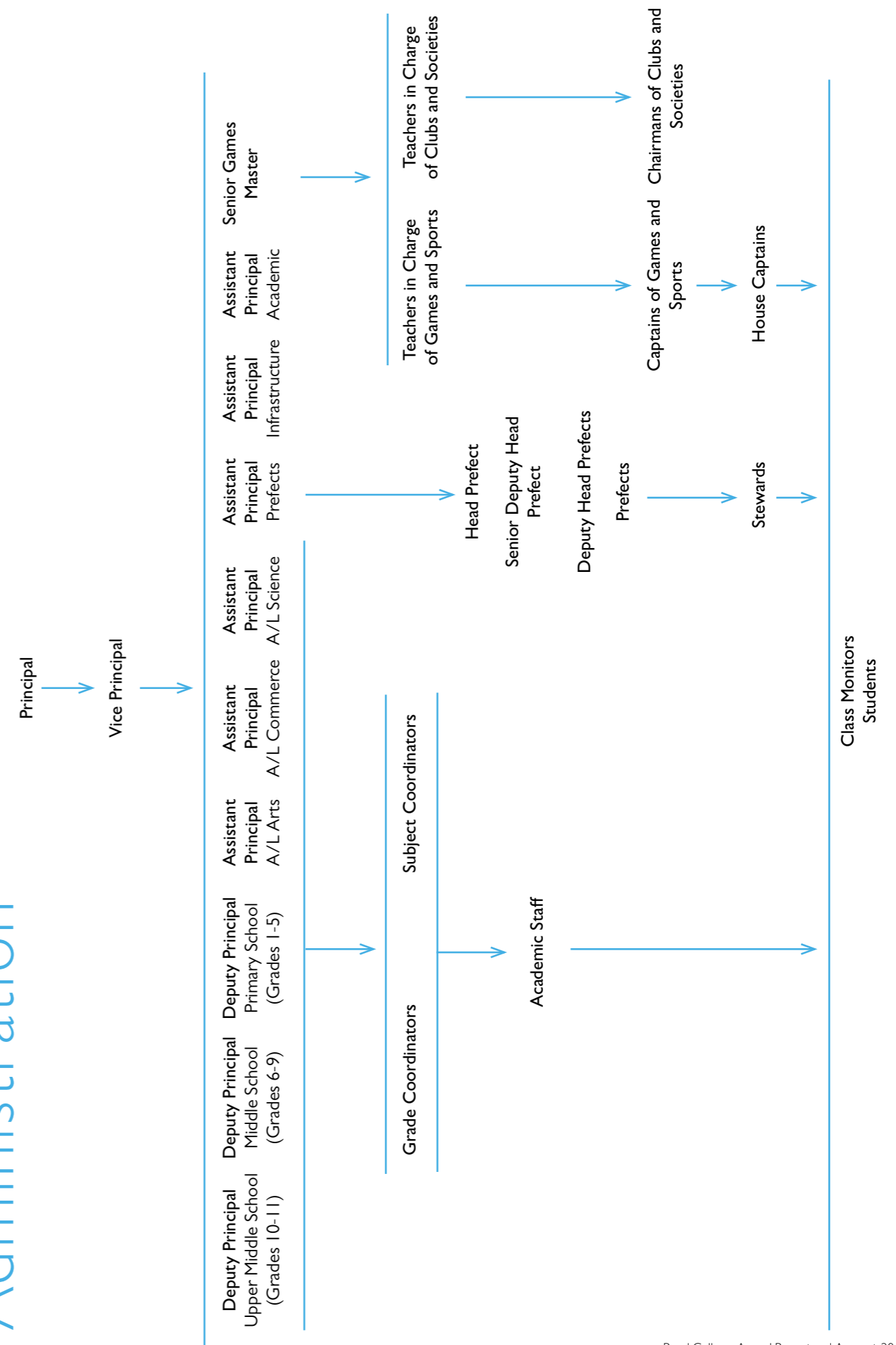

# College Crest

There is no mention of a College Crest in any document prior to 1892. Ceylon being a Crown Colony of the British Empire, the Imperial Emblem-Lion and the Unicorn was Ceylon's Badge. The Colombo academy named later Royal College being a Government Educational Institute had to use the British Royal Arms Emblem. The first display of the crest (Royal Arms) is on the cover of the first Royal College Magazine of January 1893.

In 1985 the Cricket had a simple Crest on a Blue Blazer. The Crest on the top Blazer pocket had a shield with the letter R.C. in Gold with a scroll. The word FLOREAT was embroidered in Gold letters above the Shield.

The photographs in this Chapter depict various designs of the Imperial Emblem on the Magazine cover and on the cover of books given at the College Prize Distributions. The book given as a Prize to R.A.I. Ekanayake (Cricket Captain) in 1897 has the Lion and the Unicorn Emblem. The British Royal Arms was used by the Cricketers as the Crest on a Blue Blazer from about 1905 and continued to be used till 1921. The word FLOREAT appeared above the Crest and letter R.C. below the Crest. The Royal Arms was rounded with Blue and Gold braiding resembling a Shield. The year in which the player represented the College appeared on a scroll below the Shield.



The New Royal College Arms.

"In 1922, Government sanctioned the use of the new Royal College Arms in place of the Royal Arms used in the past, in common with many branches of the Government throughout the Empire. A layman's description of the new arms will be of interest, and is as follows. --

Elliptical shield with the motto

of Disce Aut Discede, round the edge. In the shield an elephant and a palm; the shield is surmounted by the word 'Floreat', on a scroll which is in turn surmounted by a Crown. Laurel wreaths right and left of the shield and separated from it. Initials R. C. at the base where the two wreaths nearly meet. For the approved design the school is indebted to Mrs. F. D. Wijesinghe."

- History of Royal College, 1981 -

# College Song

## School of our fathers

**Thy spirit first to life awake  
In eighteen hundred and thirty five  
Beneath the sway of Marsh and Boake  
Thenceforth did lanka's learning thrive**

**Refrain :  
School where our fathers learnt the way before us  
Learnt of books and learnt of men, through thee we'll  
do the same  
True to our watchword "Disce Aut Discede"  
We will learn of books and men, and learn to play the  
game**

**Within thy shade our fathers trod  
The path that leads to man's estate;  
They have repaid the debt they owed;  
They kept thy fame inviolate.**

**Refrain  
And we their loyal sons now bear  
The torch, with hearts as sound as oak;  
Our lusty throats now raise a cheer  
For Hartely, Harward, Marsh and Boake.**

**Refrain**

Royal College the oldest public school in Sri Lanka Lagged behind other Colleges without a college song until Principal Maj. H.L.Reed composed and set to music the SCHOOL OF OUR FATHERS in the Third term of 1927. The music was later revised by S. Schmid.

A college song provides inspiration, a fervor and attachment to one's old college. To the old boys its nostalgia, of the years that were, the happy carefree boyhood days. To the young 'Ones' who now bear the torch the college song is something for every conceivable occasion. They sing themselves hoarse. They sing with pride-their own "anthem". One has to witness them rendering the college song with gusto-there's happiness written on their faces. In 1968, a shorter version of the college song in Sinhala was again composed on the instructions of the Principal by the same combination which composed the first song by Messrs. W.A. Wickramasena and S.J.F. Dissanayake.





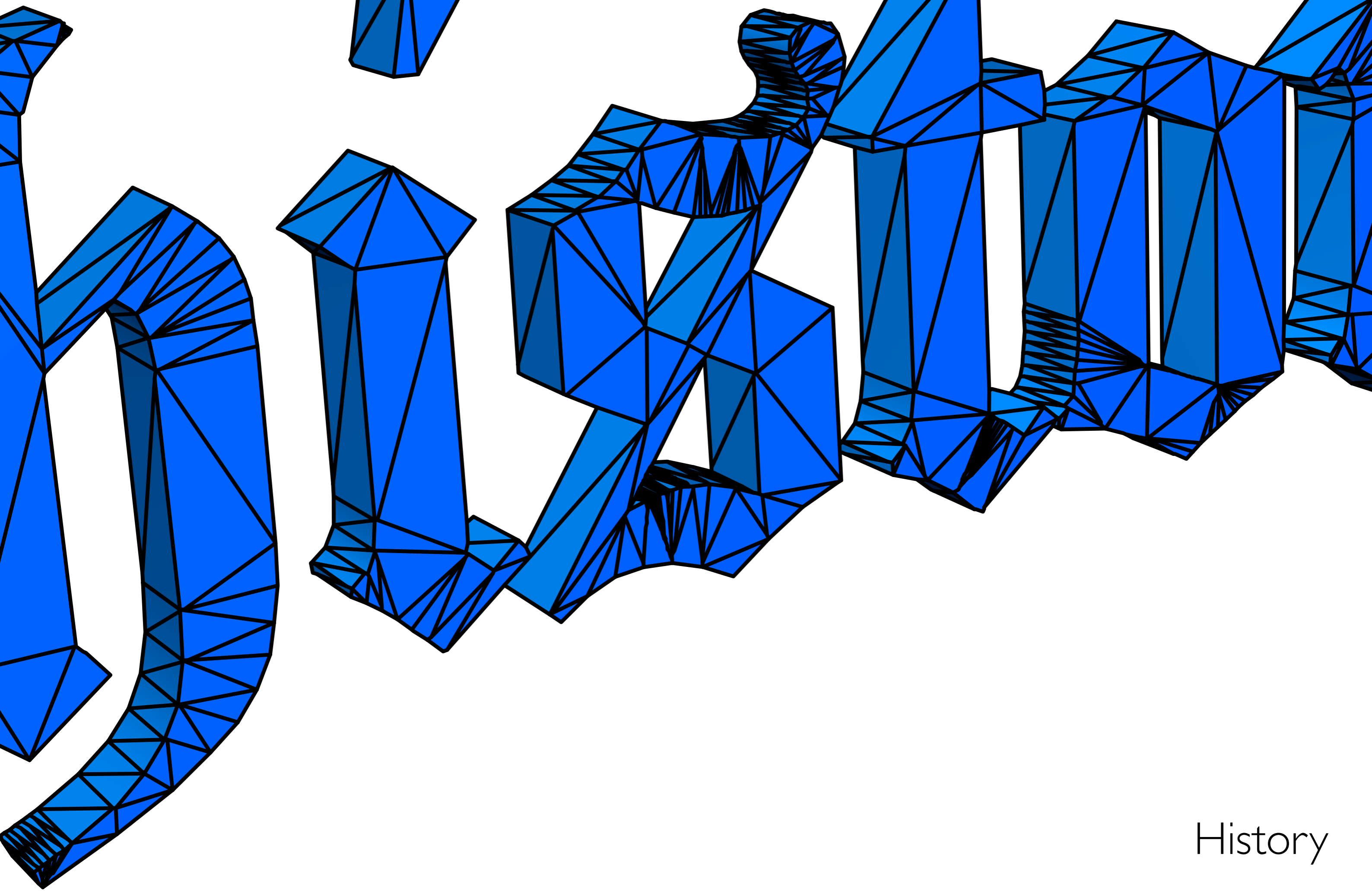

History

Royal College has an illustrious history running back a grand 175 years, from 1835 when it was founded by Rev. Joseph Marsh the acting Colonial Chaplain at St. Paul's Church as the Hill Street Academy. In 1836 Sir Robert Wilmot-Horton, the British Governor of Ceylon, based on the recommendations of the Colebrooke Commission converted it, as the Colombo Academy into an English public school modeled on Eton College, with Rev. Marsh continuing as Headmaster.



Founder  
Sir Robert Wilmot Horton  
(Governor of Ceylon  
1831-1837)



First Headmaster  
Reverend Joseph Marsh  
(1835-1838)



Prefects carrying college flag around the grounds, during the Battle of the Blues ; the longest running cricket encounter in the world

When taking a walk down the memory lane of Royal College, it is clear to see that this Majestic institution has been the pioneer of many events in the schools arena, such as Royal Thomian Big match, The Bradby Shield Encounter, and the Royal Thomian Regatta.

It also carries forward many a tradition such as the "School of Our Fathers", the College anthem, composed by Major H.L Reed in 1927 which has won the Meaden Shield 8 years in succession for the best performance in the school's singing competition since 1928. The school's motto "Disce Aut Discede" meaning Learn or Depart, is a reference to the high academic standard maintained at the school for over hundred and seventy five years. "Floreat", meaning "Flourish" also in Latin has been a motto associated with school since the founding of the Colombo Academy in 1836. Derived from "Floreat Etona", the motto of Eton College on which the academy was modeled on at its formation.



The year 2010 marks the 175th anniversary of this glorious institution, and it has indeed been one of the Golden Years in the history of College, in which it has achieved many academic, extra curricular and co-curricular targets and has been recognized both in an Island wide and on a global scale for its achievements, most famously, being named one of the "Most Innovative Schools in the world". The 175th anniversary year marks yet another milestone of a remarkable era of this Alma Mater beyond excellence, and will only be a building block for many more centuries of brilliance and splendor to follow.



Oldest building at the Rajakeeya Mawatha Premises. Presently Grade 8 block.

Since then Royal College has moved a long way from its original birthplace, in Hill Street, Pettah, to San Sebastian Hill (Now Hulftsdorp) in 1836, then in 1913 to Thurstan Road (Present University of Colombo premises) and then finally to its current location at Reid Avenue in 1923, passing many a milestone such as being named the Queen's Royal College, Sri Lanka with the consent of Her Majesty Queen Victoria in 1881, forming the 1st ever Past Students Alumni in Sri Lanka, The Royal College Union in 1891 and forming the 1st ever Cadet Contingent in the island, "The Ceylon Light Infantry" in 1881.



January to December 1835 - Hill Street Academy at St. Pauls Church Wolvehdal - back verandah.



1923 to Present: Reid Avenue (Rajakeeya Mawatha)

In 1945, Minister of Education C. W. W. Kannangara began the establishment of central colleges (Madhya Maha Vidhyala) as part of the Free Education policy to provide secondary education for the rural masses; he modeled these schools on the general structure of Royal College. Although there are several schools in parts of the island that have adapted the name Royal College in the post-independence era; none have links to Royal College Colombo nor have been received formal permission to use the Royal prefix.



The Crest of Queen's Royal College



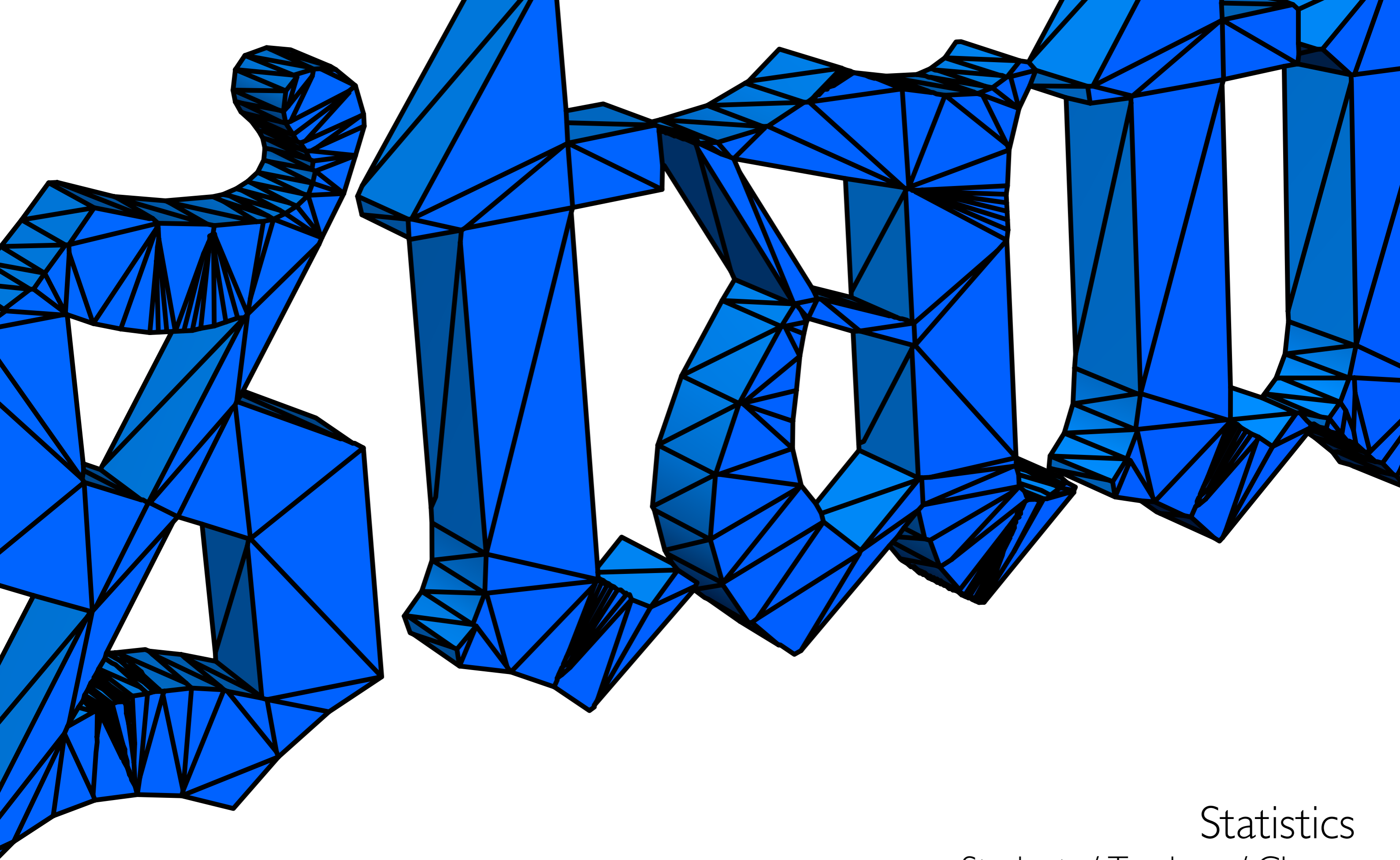

Statistics  
Students / Teachers / Classes

# Students

**Grade 1-5**  
**2279**

Tamil medium  
406 / 18%

Sinhala medium  
1873 / 82%

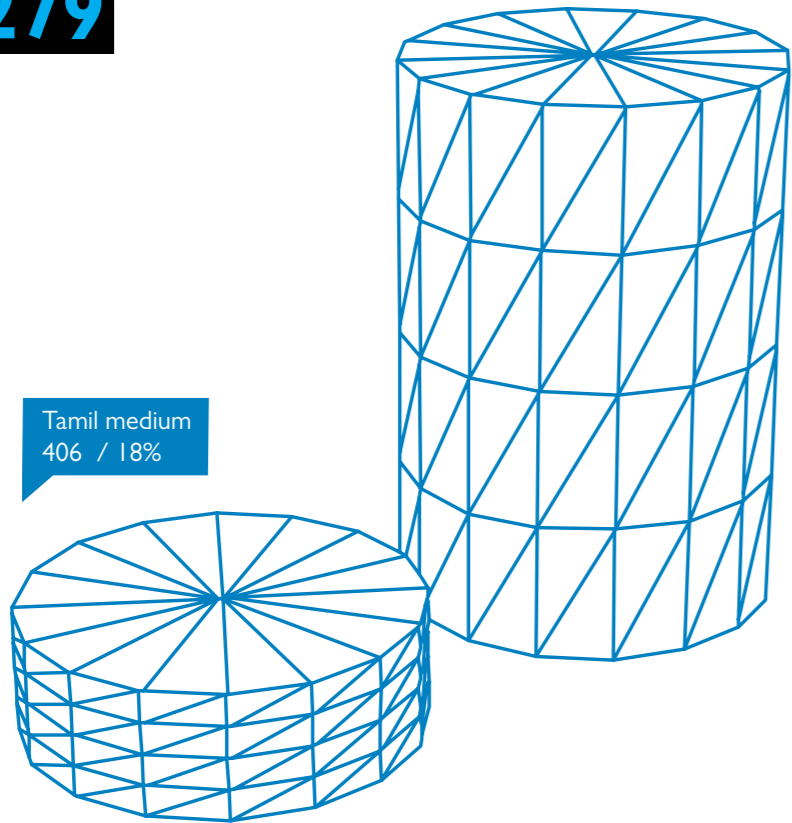

**Grade 6-11**  
**4552**

Sinhala medium  
3173 / 69%

English medium  
885 / 20%

Tamil medium  
494 / 11%

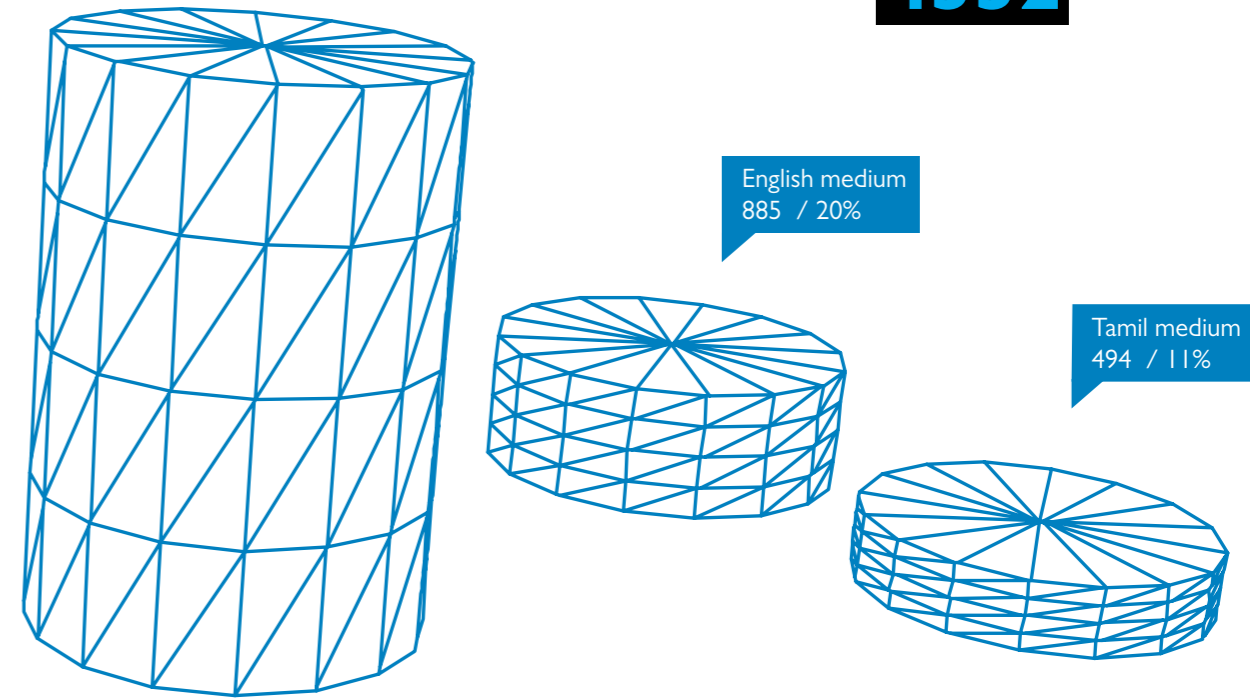

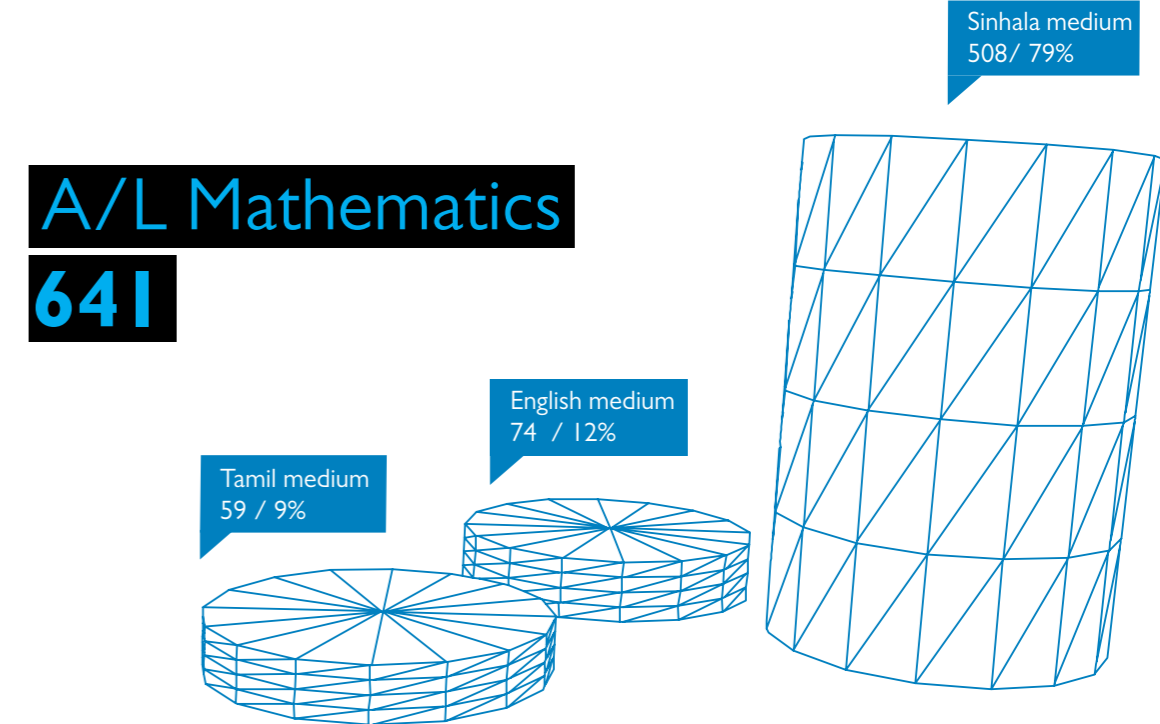
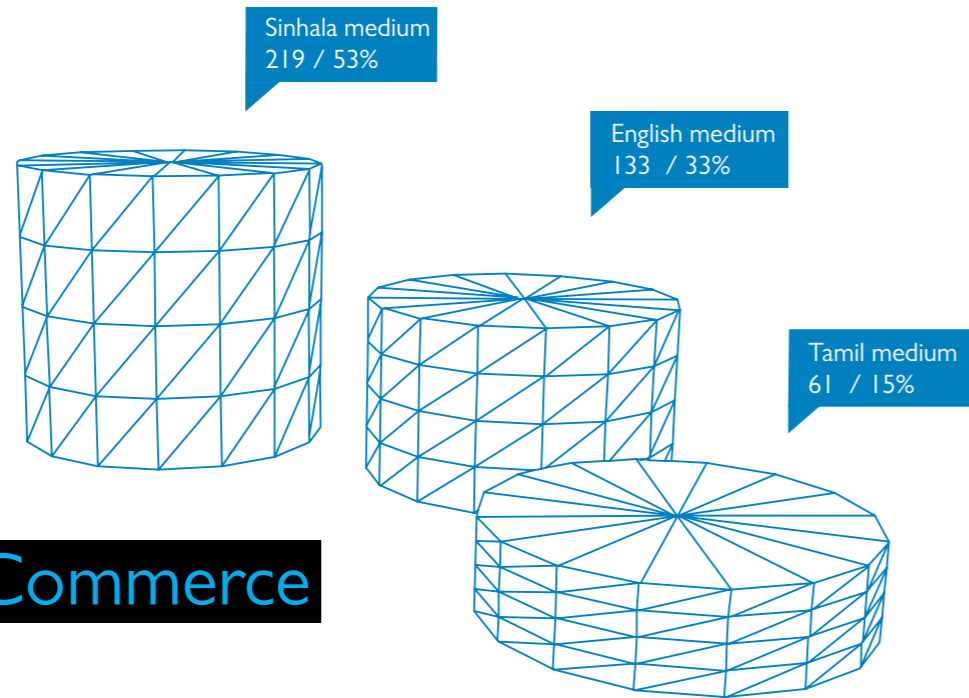
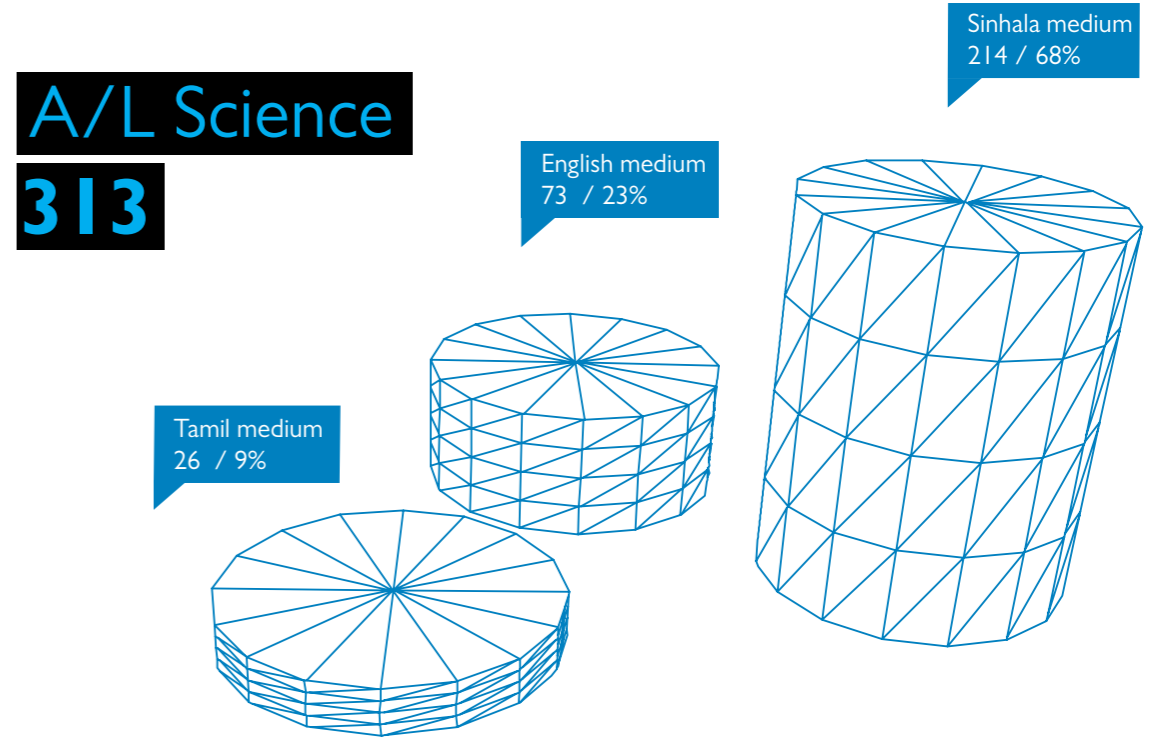
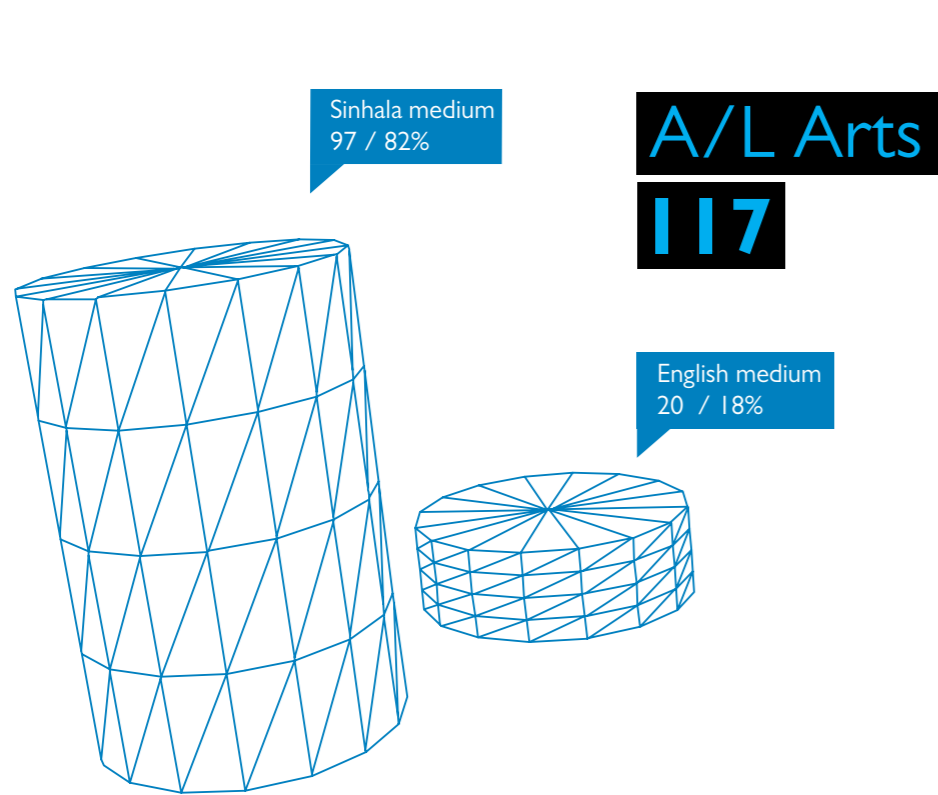

**A/L (12-13)**

**1502**

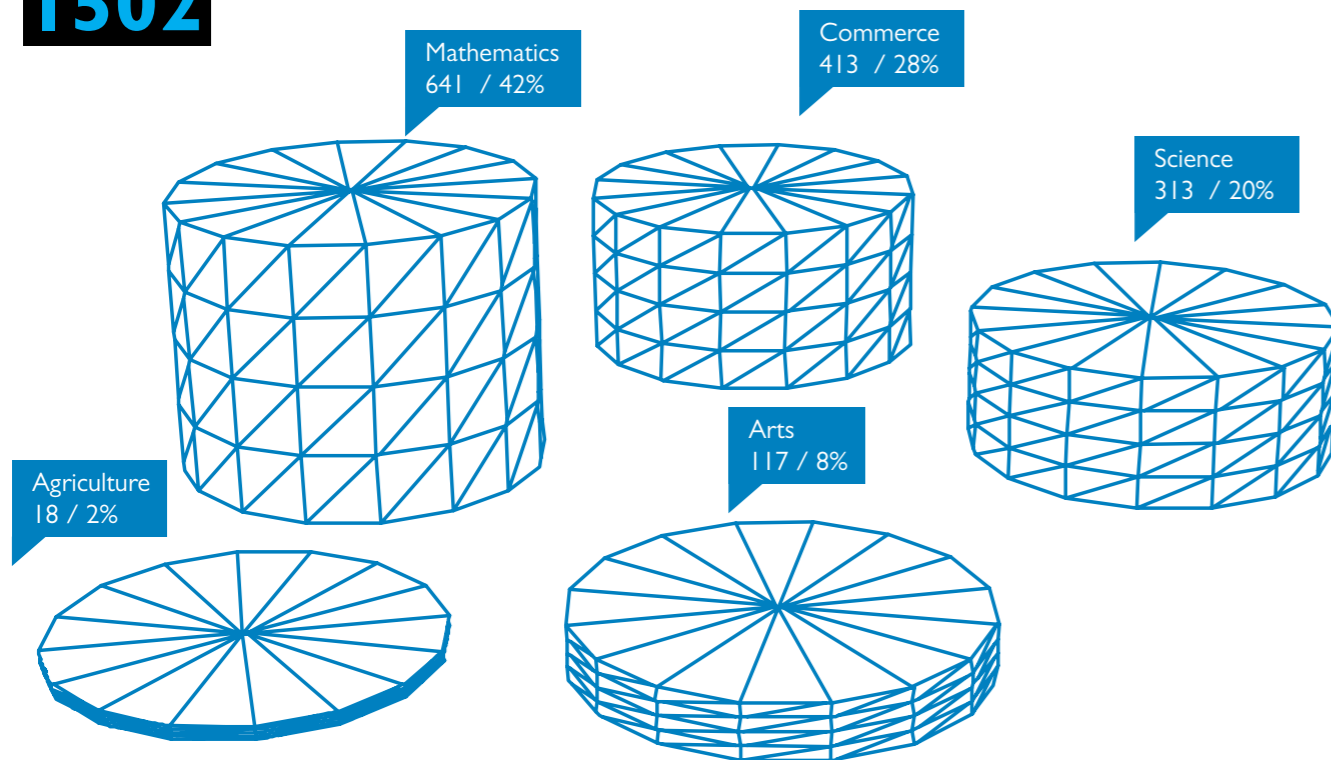

Subject	No. of Teachers
<b>Primary Section</b>	
Common	40
English	8
Second Language	3
<b>Middle &amp; Upper Middle School (Grades 6-11)</b>	
Science/Maths/English/Second language	54
Technical Subjects	10
Common	
Sinhala/Buddhism/Social studies/history/Geography/Development studies/Japanese/Entrepreneurship	50
Aesthetic Subjects	11
Health & physical	7
Other	10
<b>Upper School (Grades 12-13)</b>	
Advanced Level Commerce & Arts	17
Advanced Level Science	24
Advanced Level Additional subjects	8
English Medium 6-11	6
Advanced Level English Medium	6
SDS Staff	36
<b>Total</b>	<b>290</b>



# Classes

	Sinhala Medium	Tamil Medium	English Medium
Primary School	40	10	-
Middle School & Upper Middle School	59	12	18
Upper school – Arts Section	04	-	01
Upper school – Commerce Section	06	02	04
Upper school – Science Section	06	02	02
Upper school – Maths Section	14	02	04
Upper school – Agri Section	02	-	-
<b>Total</b>	<b>131</b>	<b>28</b>	<b>29</b>
<b>Total no. of classes</b>			<b>188</b>

## Primary School

**2279**  
Students

**46**  
Teachers

**50**  
Classes



## Middle school & Upper middle school

**4552**  
Students

**147**  
Teachers

**89**  
Classes



## Upper school

**1502**  
Students

**97**  
Teachers

**49**  
Classes



**8333**  
Students

**270**  
Teachers

**188**  
Classes

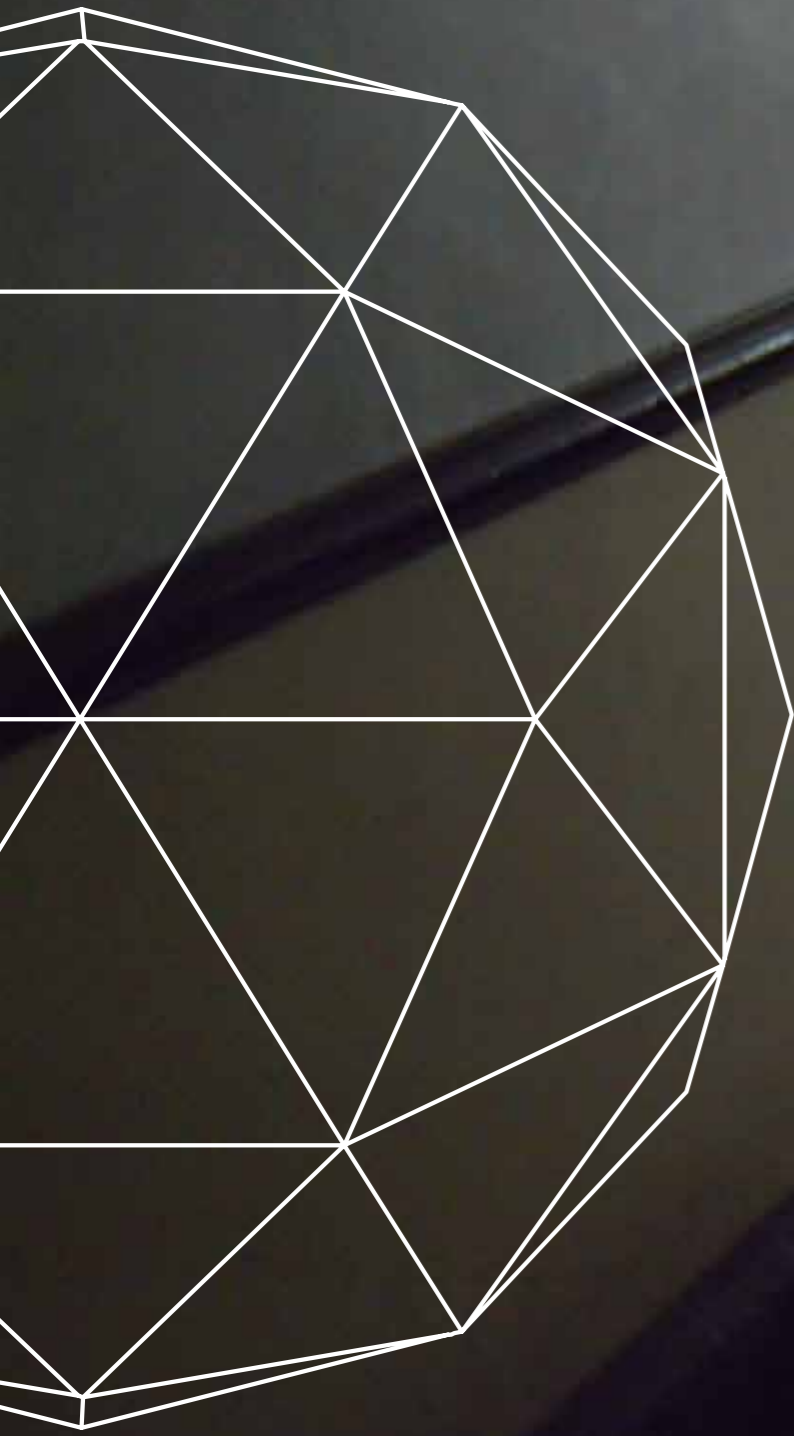

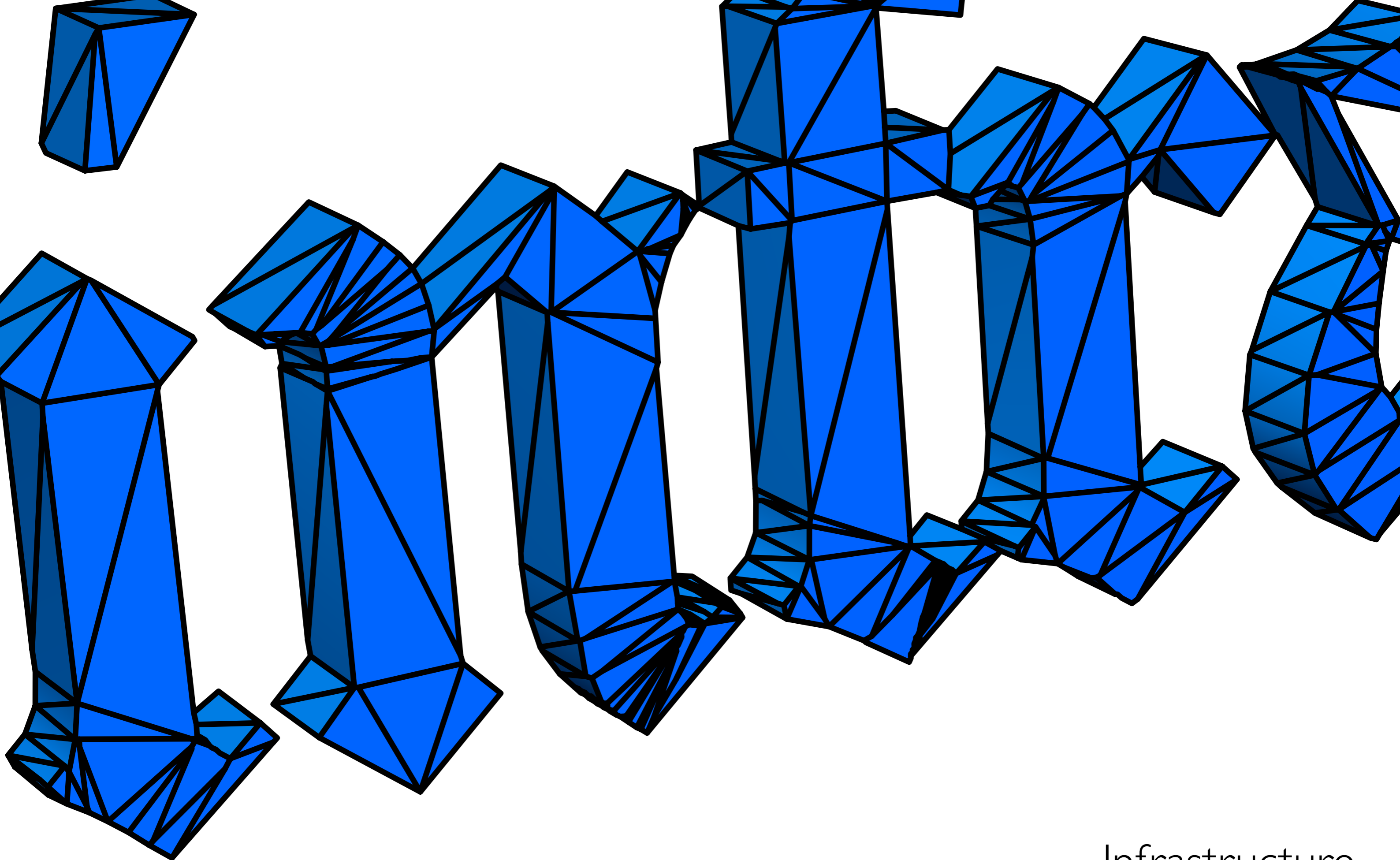

Infrastructure

# Hostel

The Royal College Hostel is a “Home away from Home” for around 550 students, with the senior hostel having 300 students who come from different areas of the island including 12 hostel prefects. The newly built junior hostel building can accommodate up to 250 students. The Management of the Royal College Hostel is under the supervision of the Principal, Senior Deputy Principal, Warden and Sub-Warden while the Board of Prefects join hands and perform their respective duties.



The Management always makes arrangements to provide the hostelers with a nutritious, balanced diet. The charges are reasonable when compared with the facilities they are provided with. The tutorial staff serves with a sense of dedication and commitment by imparting knowledge as well as promoting attitudes and skills of the hostelers.



# Cafeteria and Dining Facilities

Royal College has two main cafeterias for the Upper school section and the Middle school section while the junior school is provided with a milk bar.

The Main cafeteria can house more than 100 students at a time, with modern dining facilities which can be used by students during the interval and before and after school hours. It provides a wide range of Sri Lankan dishes for both breakfast and lunch for students with many types of short-eats for the intervals.



# Library

The College library is one of the oldest and largest libraries in Colombo, having reference and a lending section and a new Reading section. The reference section provides papers, Magazines, VCD's, VHS tapes and reference library services where many rare and valuable books are available for reference in a wide range of books from Science through literature to sports magazines. The Library also provides the weekly newspapers, on display to both students and teachers. It has also been given its own wireless network, and

the whole Library is a Wi-Fi enabled area. The junior school has its own library, which includes an interactive learning process with newly built structure and modern furniture to attracting young readers.



# Computer Labs

Royal College as one of the Leading Innovative Schools of the world has developed rapidly in the field of Information & Communication Technology (ICT). Royal currently posses 5 highly equipped Computer Laboratories in all sections of the school. At Present even Primary Students are given access to use computers at these Computer centers.

The following are the details of the Computer Centers

1.Lab 1	40 P.C's	Reserved for Primary Section Students
2.Lab 2	40 P.C's	Reserved for Students from Grade 6 to 13
3.Lab 3	60 P.C's	Reserved for advanced Level Students
4.Lab 4	90 P.C's	Reserved for Students from Grade 6 to 11
5.Lab 5	40 P.C's	Reserved for Students from Grade 6 to 9



Royal College is also home to the one of 10 Interactive White Boards in the island.

It is a modern day teaching tool, which helps teachers to manage their work as well as help teach students in an efficient manner. 10 Interactive White Boards were donated to Sri Lanka by Canada in the year 2009 and one was donated to Royal College.

About 50 Teachers are trained to use this board and use it for classroom activities. This is one of the most recent infrastructural achievements of Royal College.

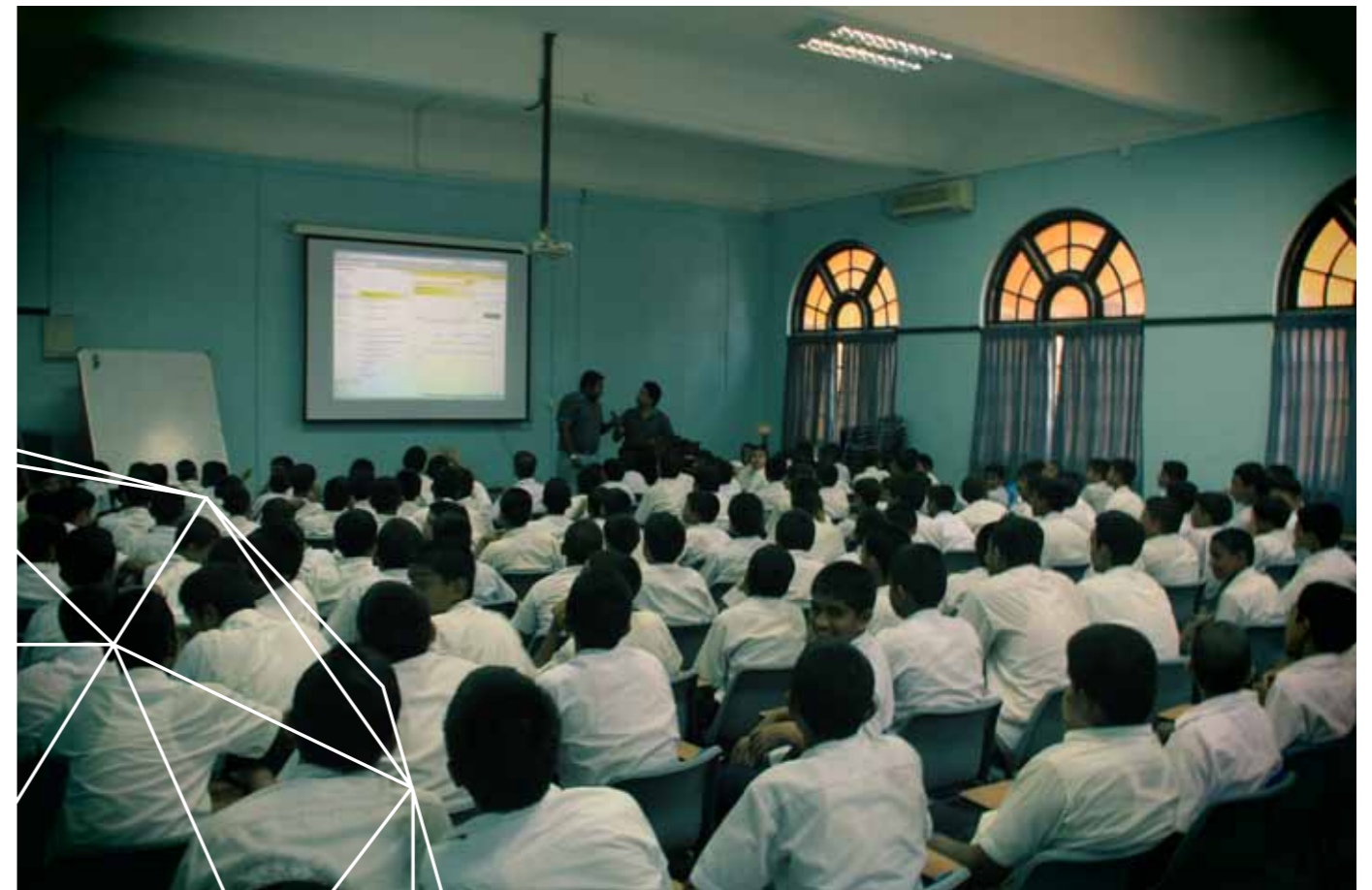

# Sports Complex

The Royal College Complex is one of the biggest Multi-purpose sports centers in the island, which includes one of the largest Rugby fields, accommodating over 12000 spectators which is the venue for the popular Bradby Shield Encounter and the Royal Thomian Soccer match. The Royal College Complex also includes a multi-purpose indoor stadium which is used for Basketball, Table Tennis, Badminton and Volleyball. The Sports Complex also has the first ever school-owned Squash courts and also a multi facility Gymnasium, which can be used at half-rate by Royal College students.



# Cricket Grounds

The Royal College Cricket Grounds, commonly known as the Reid Avenue Grounds, is the home to the Royal College Cricket team, including of a vintage ivy scoreboard, turf side nets, indoor cricket nets and a massive pavilion accommodating up to around 3000 named after Old Royalist, Past Head Prefect and Sri Lanka's 1st ever executive President, His Excellency J.R. Jayewardene, which also includes dining and lodging facilities for touring teams.



# Swimming Pool

The swimming pool at Royal College is 33 and 1/3m in length and includes 8 lanes and also a fully equipped 1m and 3m springboards, and the platform for diving. The pool also has a functioning set of floodlights to stage both day and night Meets and Water polo matches.





# Basketball Courts

The Royal College Basketball courts include two flood-lit courts which have been recently renovated by the School Development Society. It is also being upgraded with a new pavilion and scoreboard.



# Boxing Ring

Royal College is one of the only schools to own a Boxing Ring of their own. It was built as an initiation of one of the most distinguished old Royalists, Mr. Dian Gomes. The Royal College Boxing Ring is built to international standards and dimensions with portable capability. It is used for most National Level Boxing Competitions including the recently concluded SAARC Boxing Trials.



# Navarangahala

The Navarangahala (New Theater) is one of the main national theatres of Sri Lanka. Built between 1966 and 1969 as the Royal Primary School Hall it was specially designed for local drama and music which required open air type auditoriums. Until it was built, there were no purpose-built indoor theatres for the local arts, apart from the few open air amphitheatres.

On the May 22, 1972 the House of Representatives of Ceylon met at the Navarangahala and finalized and approved the

Republic Constitution, thereby proclaimed establishment of the Republic of Sri Lanka, by raising the Lion Flag, for the first time in Sri Lankan history, on the Navarangahala flag pole.

Presently it has been expanded with the addition of 2 balconies, built-in stage lights and sounds and a Video Projector, with the ability to capacitate around 2000 students at a time.

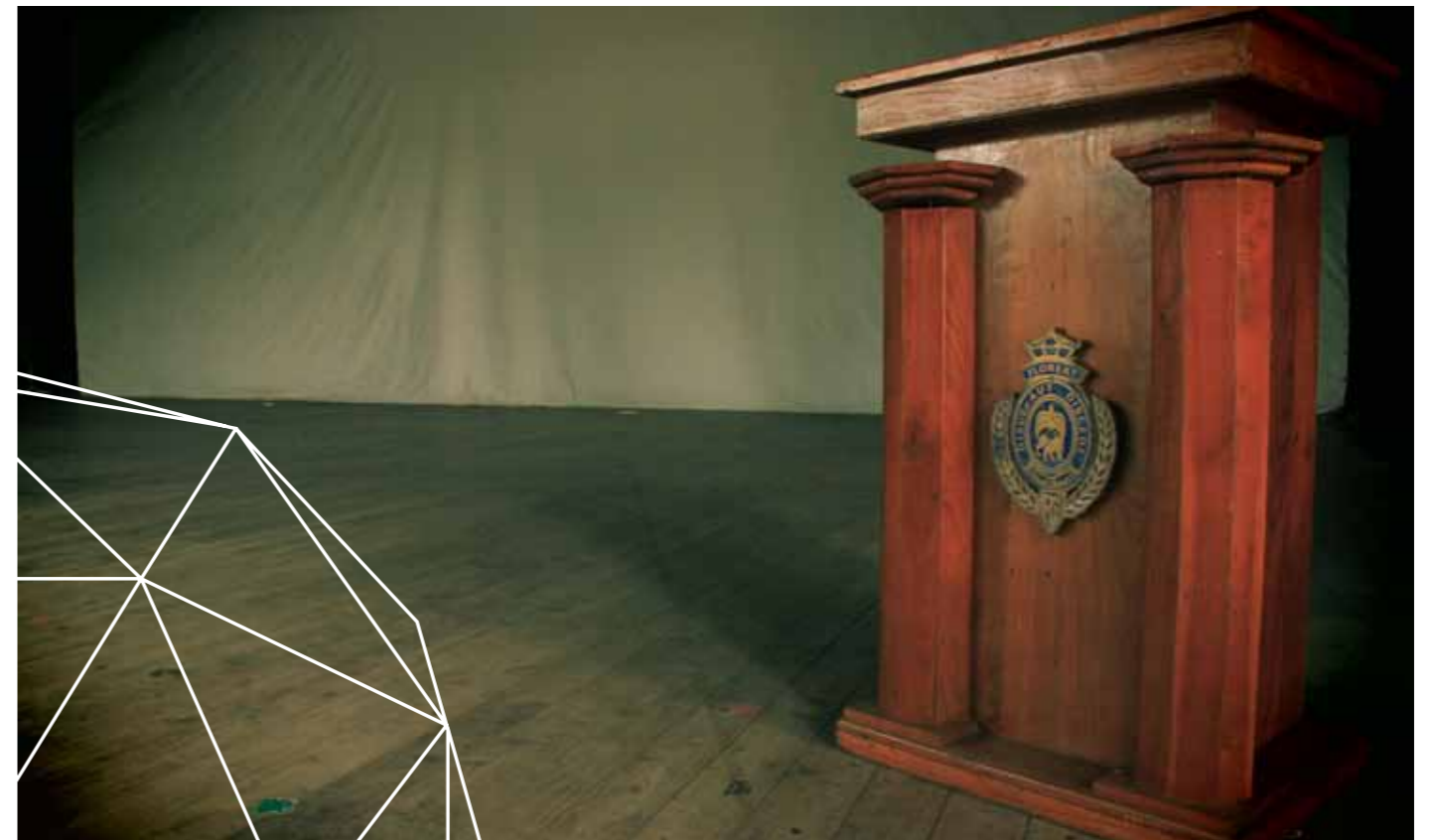



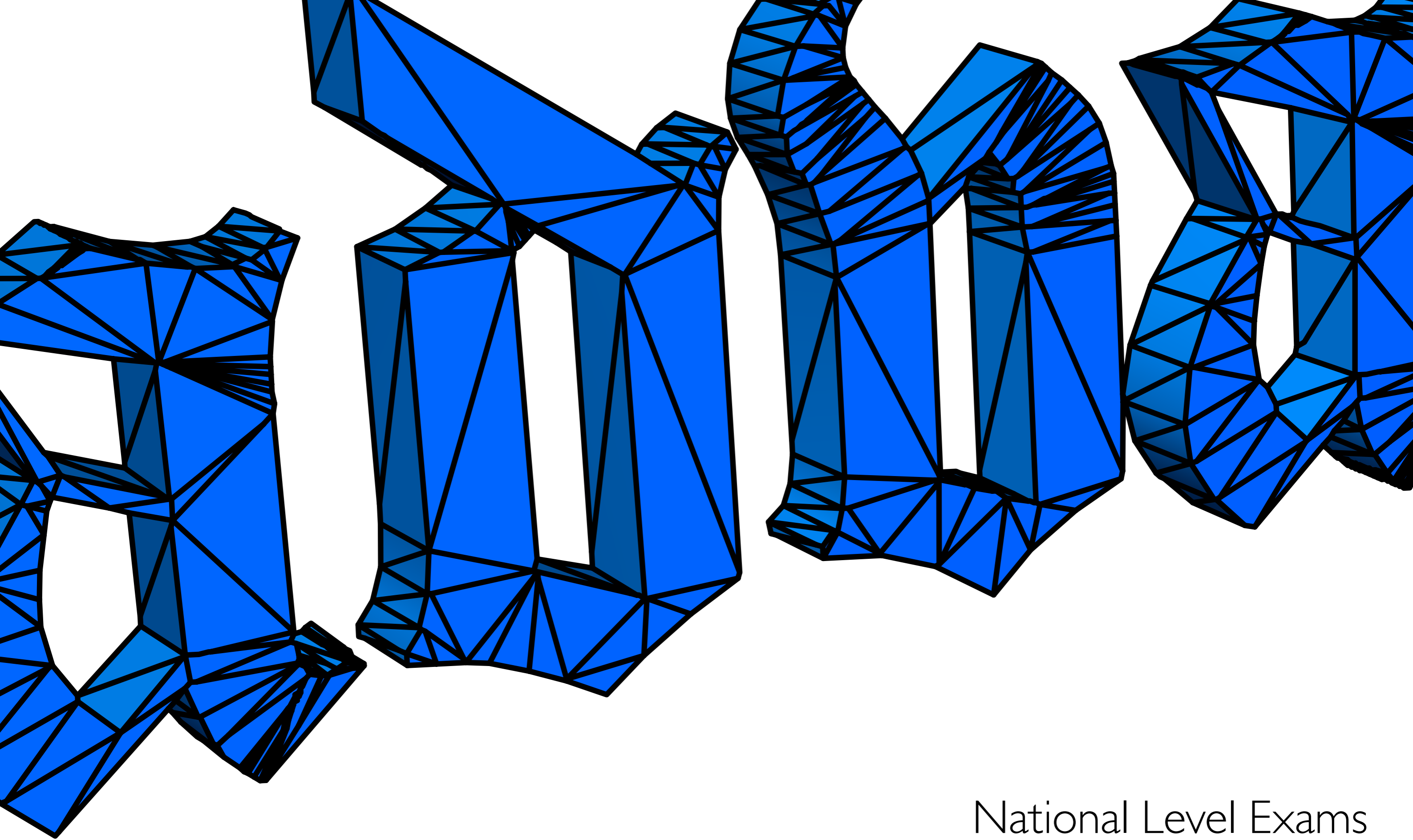

National Level Exams  
Results Analysis

# GCE Advanced Level Examinations 2010

## Sinhala Medium

### A/L Bio Science

1st sitting : 107

Pass rate : 75%

3 A's : 9  
3 F's : 4

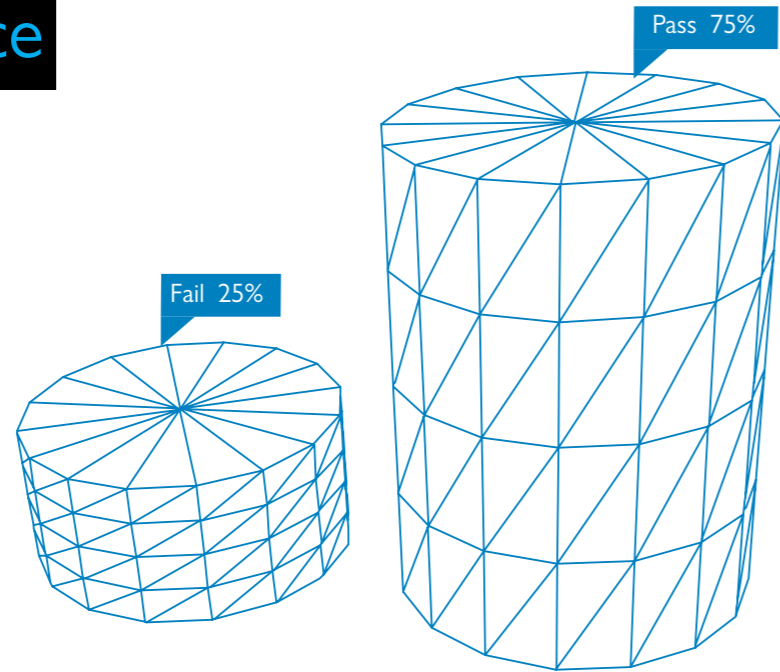

### A/L Mathematics

1st sitting : 257

Pass rate : 56%

3 A's : 15  
3 F's : 29

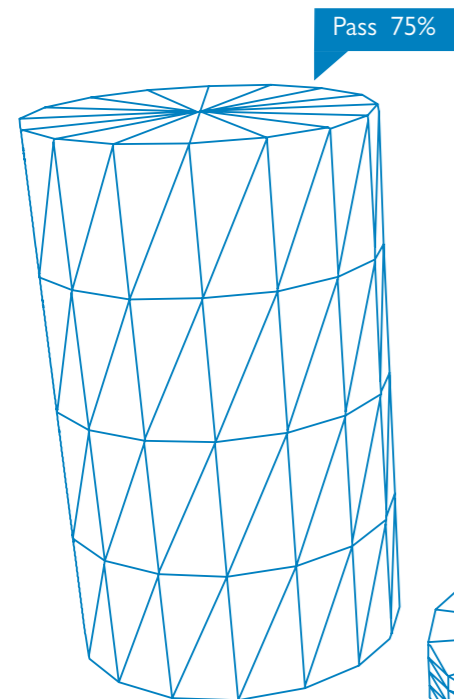
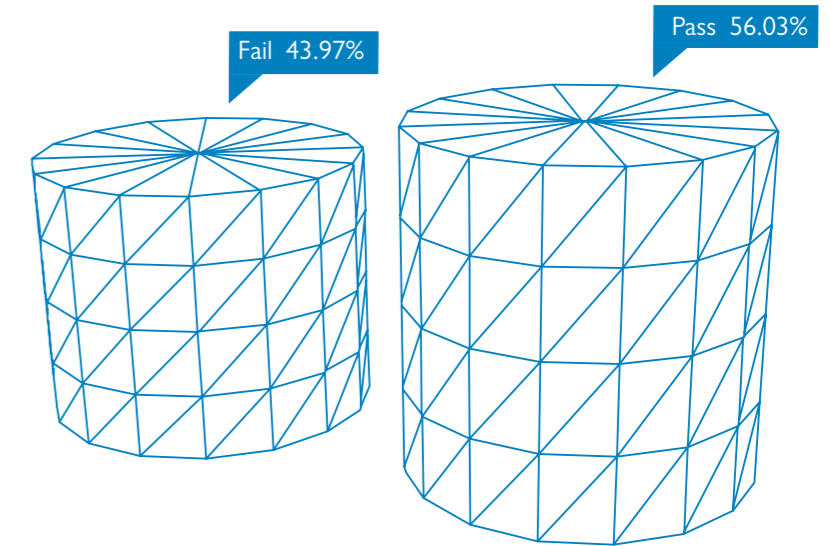

### A/L Bio Science

2nd sitting : 70

Pass rate : 90%

3 A's : 2  
3 F's : 0

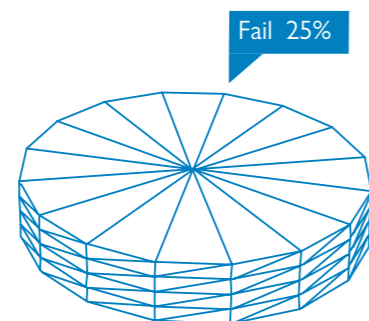

### A/L Mathematics

2nd sitting : 145

Pass rate : 68%

3 A's : 9  
3 F's : 3

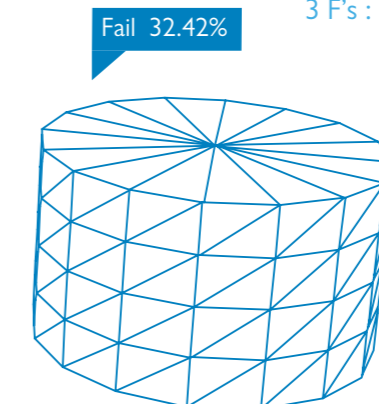
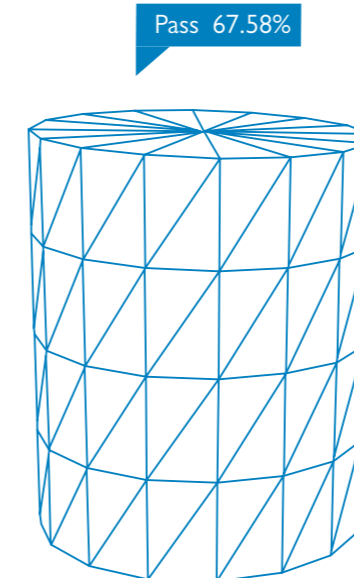

### A/L Commerce

1st sitting : 107

Pass rate : 65%

3 A's : 12  
3 F's : 2

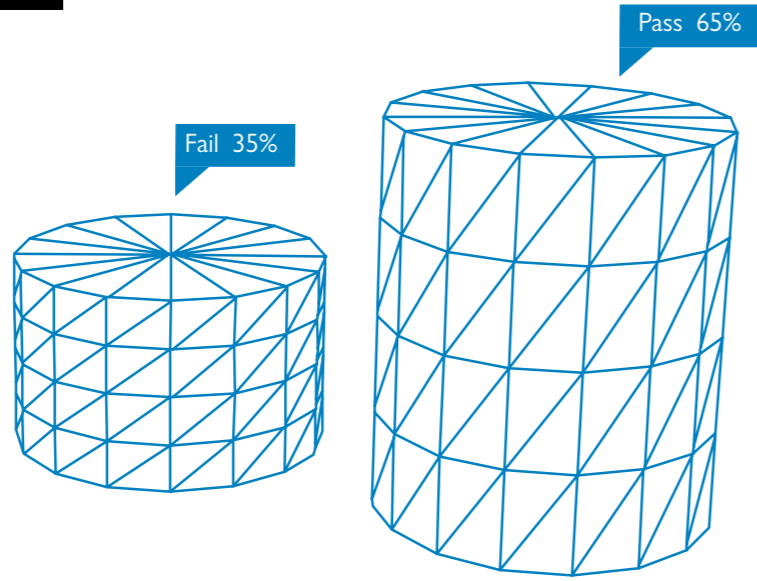

### A/L Arts

1st sitting : 58

Pass rate : 52%

3 A's : 7  
3 F's : 8

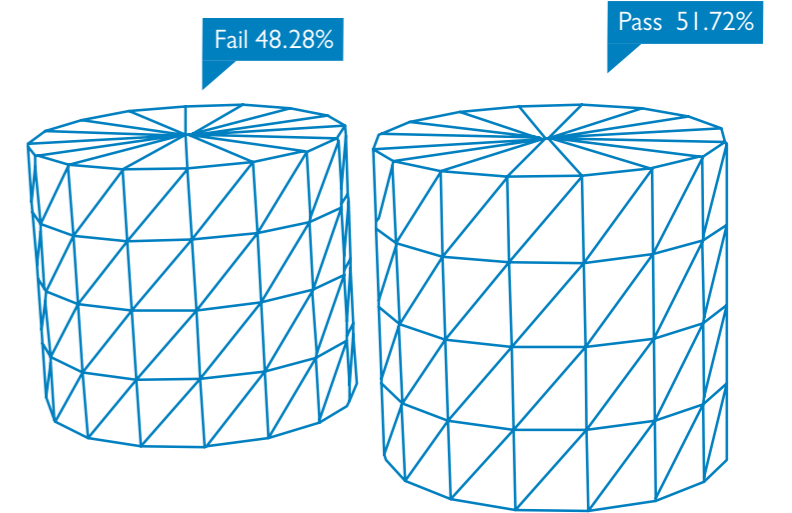

### A/L Commerce

2nd sitting : 16

Pass rate : 56%

3 A's : 1

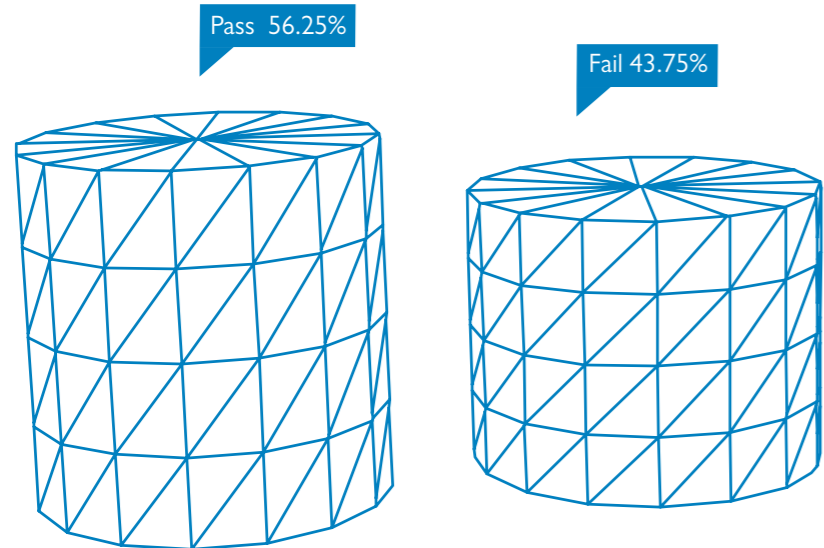

### A/L Arts

2nd sitting : 12

Pass rate : 83%

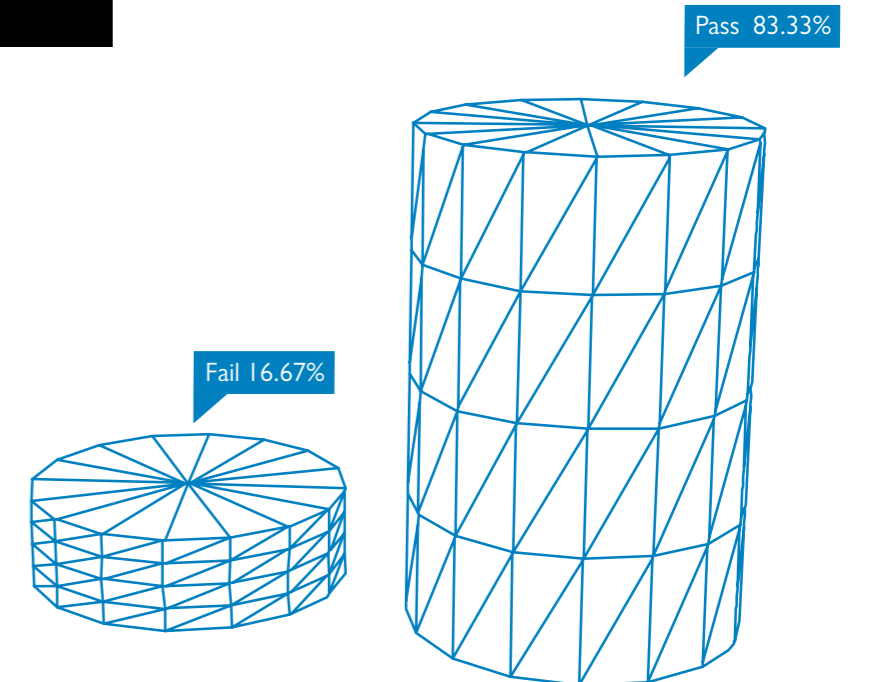

### A/L Bio Science

1st sitting : 19

Pass rate : 53%

3 F's : 2

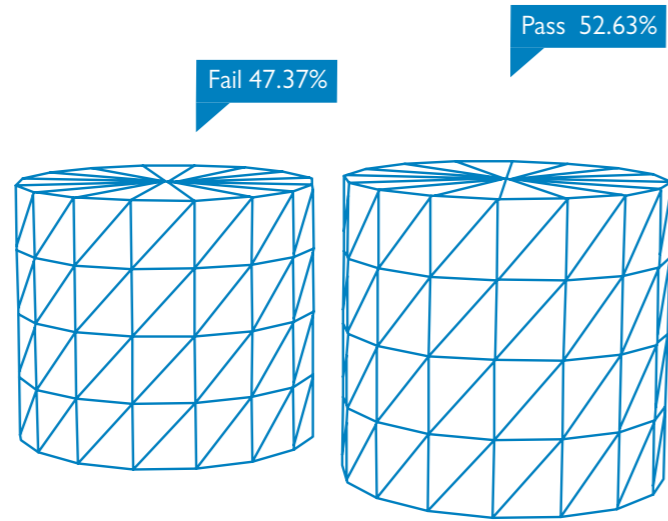

### A/L Mathematics

1st sitting : 25

Pass rate : 64%

3 A's : 3  
3 F's : 4

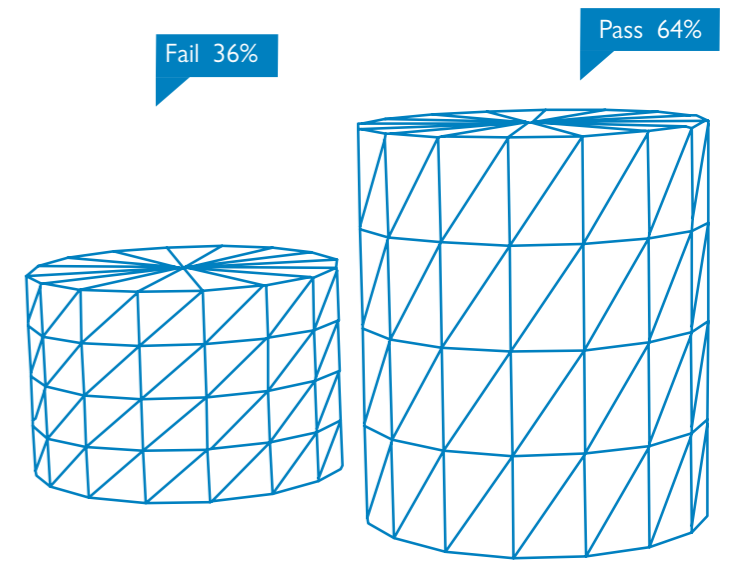

Pass 87.5%

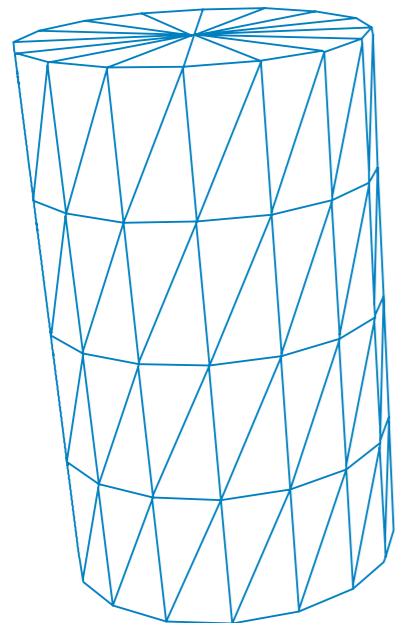

### A/L Bio Science

2nd sitting : 8

Pass rate : 88%

3 A's : 1  
3 F's : 1

Fail 12.5%

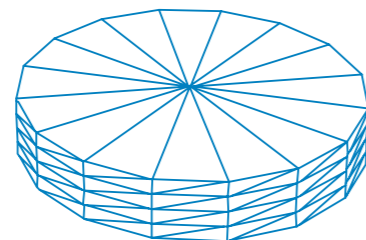

### A/L Mathematics

2nd sitting : 9

Pass rate : 55%

3 F's : 1

Pass 55.55%

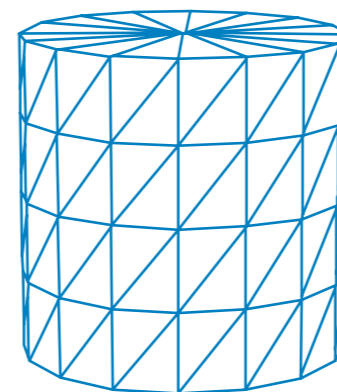

Fail 44.45%

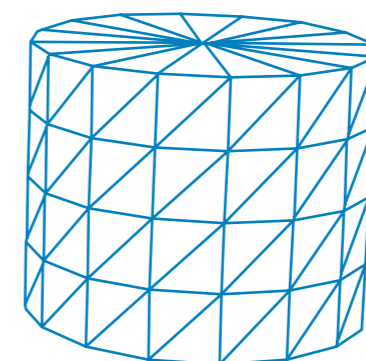

# Tamil Medium

## A/L Commerce

Ist sitting : 28

Pass rate : 79%

3 A's : 2

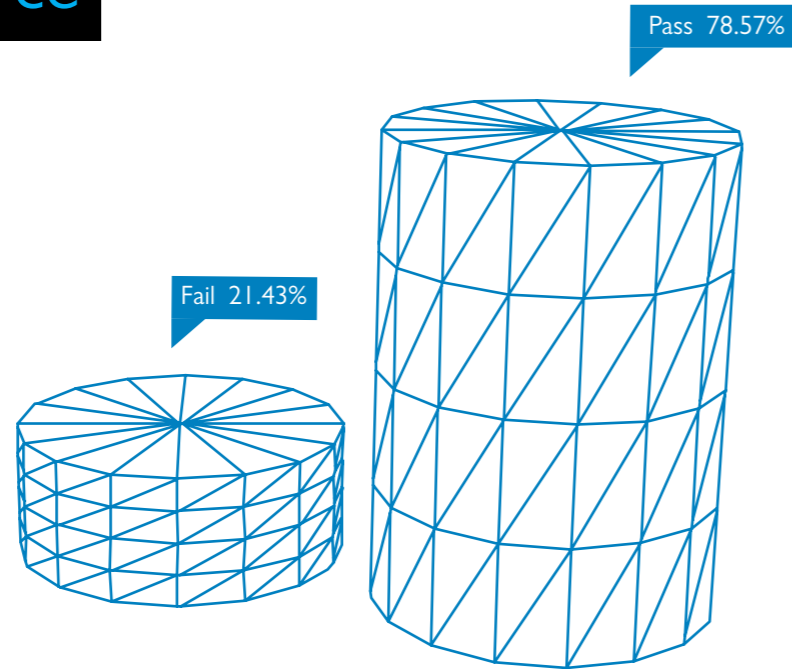

# English Medium

## A/L Bio Science

Ist sitting : 19

Pass rate : 84%

3 A's : 3

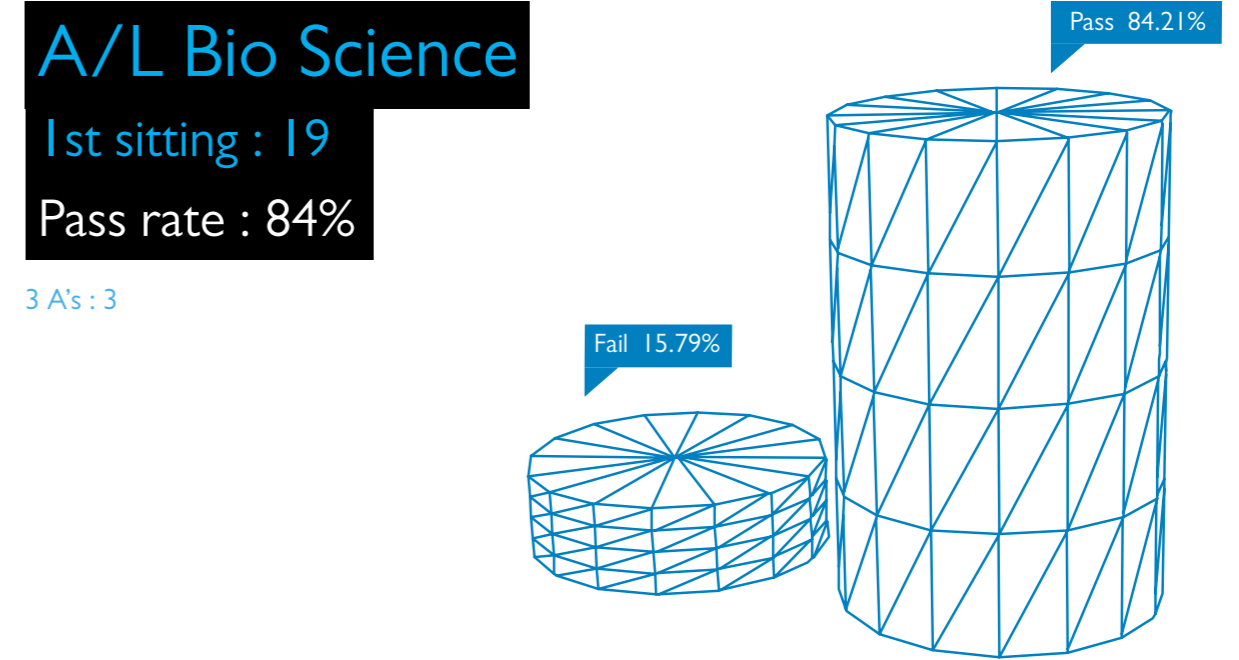

## A/L Bio Science

2nd sitting : 2

Pass rate : 50%

3 A's : 2  
3 F's : 0

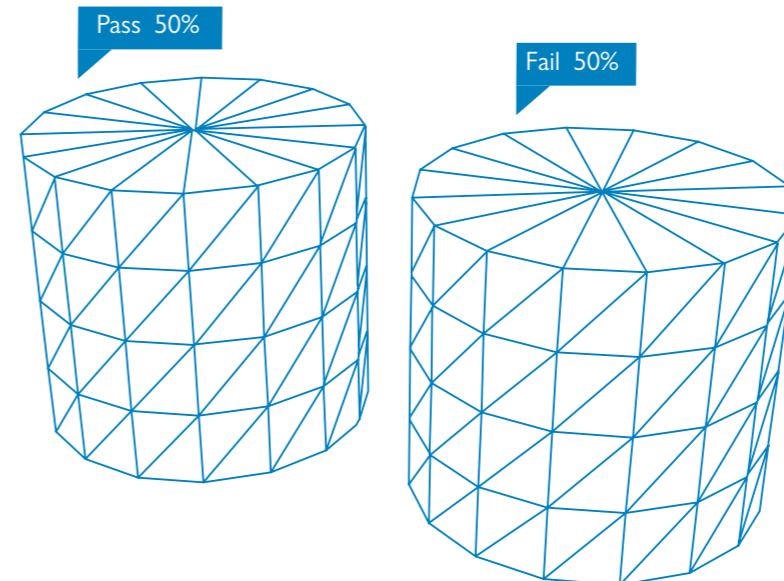



### A/L Mathematics

1st sitting : 46

Pass rate : 46%

3 A's : 1

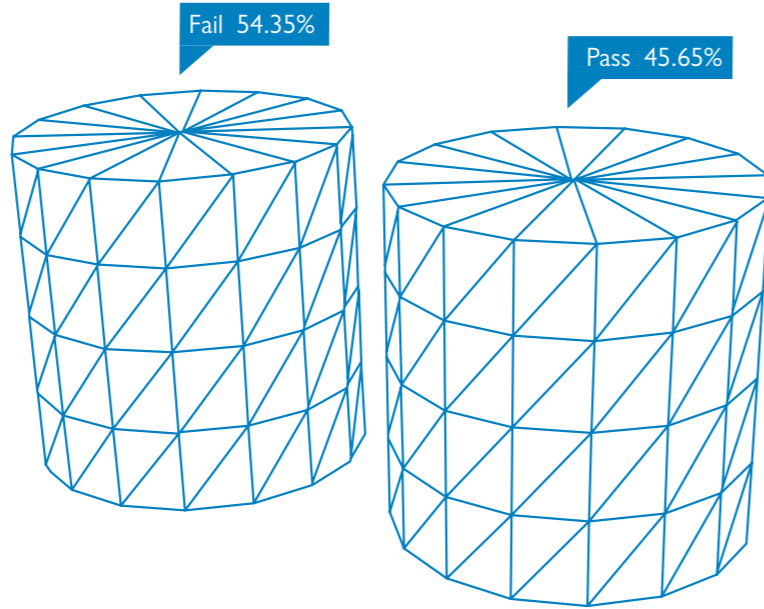

### A/L Commerce

1st sitting : 62

Pass rate : 68%

3 A's : 1

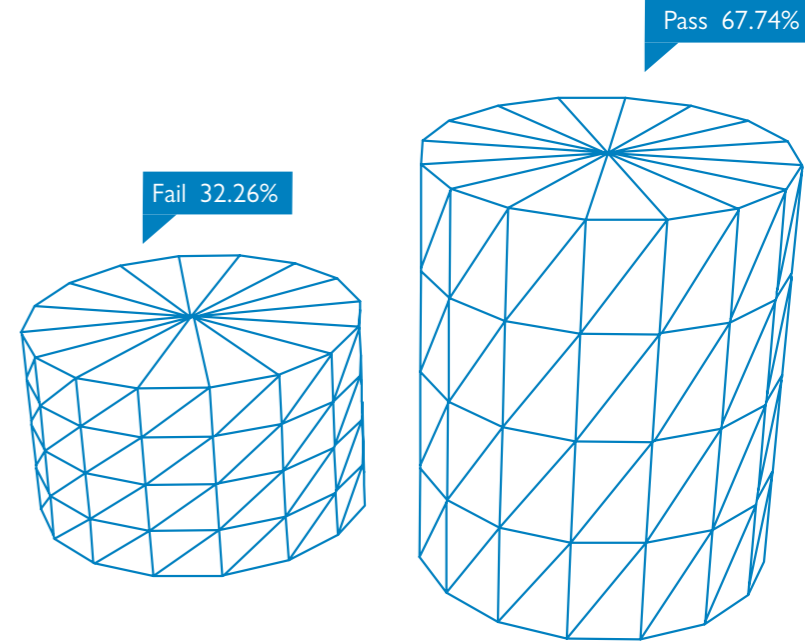

### A/L Mathematics

2nd sitting : 145

Pass rate : 68%

3 A's : 9  
3 F's : 3

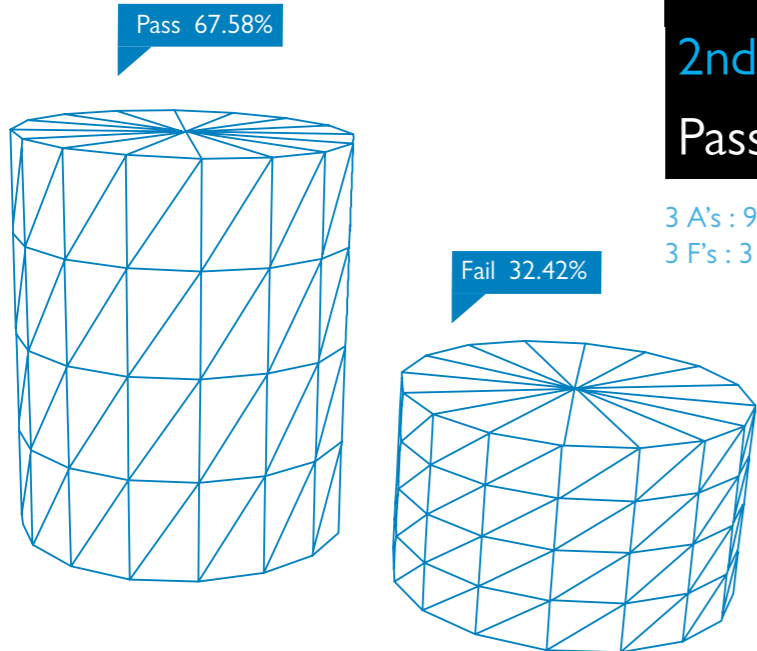

### A/L Arts

1st sitting : 1

Pass rate : 100%

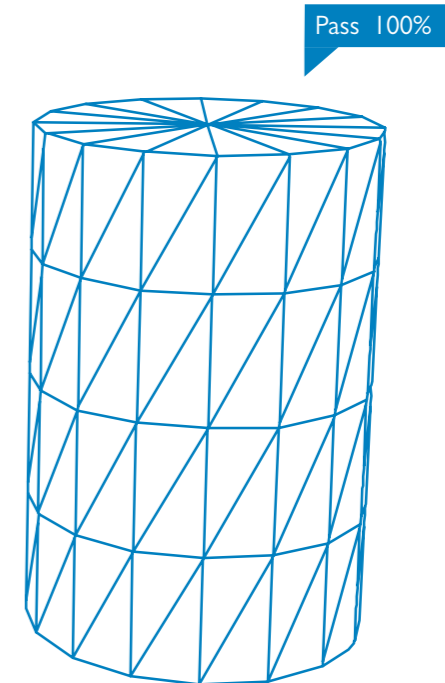

# Summary

## Sinhala Medium

Students : 772

Pass rate : 65.28%

3 A's : 55  
3 F's : 46

## English Medium

Students : 134

Pass rate : 60.44%

3 A's : 5  
3 F's : 1

## Tamil Medium

Students : 92

Pass rate : 65.21%

3 A's : 6  
3 F's : 8

# GCE Ordinary Level Examinations 2010

Subject	No. of applicants	A's	Fail	Pass	Pass rate %
Buddhism	511	375	1	510	99.80
Islam	62	20	2	60	96.77
Hinduism	49	24	1	48	97.96
Christianity	28	17	1	27	96.43
First language (Sinhala/Tamil)	665	261	7	658	98.95
English	653	513	6	647	99.08
Science and Technology	650	325	11	639	98.31
Mathematics	664	454	17	647	97.44
History	661	328	8	643	97.28
<b>Aesthetic subjects</b>					
Art	118	17	13	105	88.98
Oriental Music	79	45	0	79	100.00
Western Music	24	9	1	23	95.83
Karnatik Music	7	2	0	7	100.00
Dancing	13	1	0	13	100.00
English Literature	228	30	17	211	92.54
Tamil Literature	25	9	3	22	88.00
Drama and Theatre Studies	92	65	0	92	100.00
<b>Technical Subject</b>					
Business Studies and Accounting	346	243	9	337	97.40
Agriculture	29	19	0	29	100.00
Information & Communication Technology	142	86	0	142	100.00
Communication & Media Studies	26	10	1	25	96.15
Design & Construction Studies	47	18	0	47	100.00
Health & Physical Studies	461	232	2	459	99.57
<b>Other</b>					
Geography	35	27	2	33	94.29
Civics	11	2	0	11	100.00
Entrepreneurship	11	2	0	11	100.00
Second Language (Sinhala/Tamil)	10	2	0	10	100.00



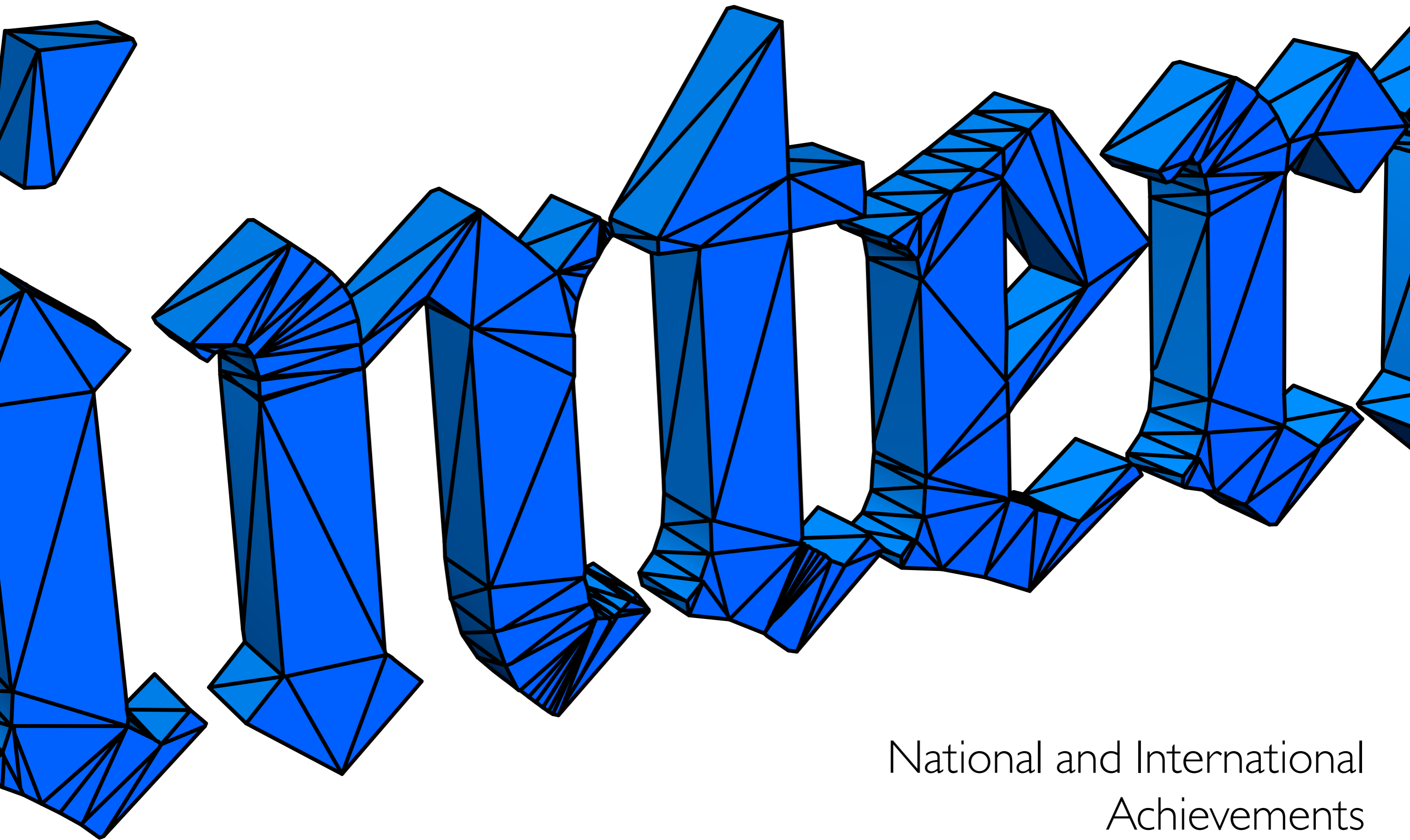

National and International  
Achievements

# Most Innovative School in the World

The Innovative Schools program is a part of the Microsoft Partners Learning program, which aims to help school leaders transform their school communities into environments that foster innovative teaching practices and 21st-century learning. The program is built on findings from 12 pioneering Innovative Schools, including the School of the Future in Philadelphia, that have successfully moved beyond the limits of the classroom and traditional learning models. With Mentor Schools, Pathfinder Schools and Participant Schools, there are now more than 2,500

schools in the program worldwide. After a thorough evaluation of the applications received from thousands of schools across more than hundred countries in the world, Royal College has beaten many schools in all the countries and managed to place its name at the first slot in the list. In May 2009, there was a local competition organized by Microsoft Sri Lanka in coordination with the Ministry of Education to select 5 most innovative schools in the country. Royal College took part in this competition and was selected together with another four schools to represent Sri Lanka

in the global competition. In July 2009 we submitted our application to the Microsoft Corporation for consideration. Microsoft has evaluated the achievements of each school in following areas.

1. Academic Success
2. Innovation Culture
3. Leadership Development
4. Learning Community
5. Strategic Development Planning
6. Innovative Use of ICT

In 2010, the Microsoft Corporation announced Royal College as one of the Most Innovative Schools in the world.



## Using Radio Frequency Identity Card (RFID)

to which every parent has access, so that they can find the exact time their children entered the school.

Another noticeable use of modern technology is the introduction of RFID (Radio Frequency Identity Card). All the students above Grade 3 are entitled to this special facility. They have to mark their attendance at the gate as they enter the school in the morning.

In fact this is an easy way for the parent to find out whether their child had entered the school premises safely. There is a website



# Agriculture

The agricultural society of Royal College emerged as the runners up in the “Ran Aswenu Mangallaya” organized by the Sri Lanka Rupawahini Corporation under the guidance made by the current government. The theme of this all island agricultural competition is- “api wawamu rata nagamu” and in this competition schools from all parts of the island competed in order to be crowned as the best agriculture society in a school around the island.

The criteria's which were judged are as follows,

- The most productive agriculture society
- The school which had the best pest and disease control
- Organic manure usage and production
- Various ways to produce compost
- The amount of various vegetable, fruits and herbs
- Urban agriculture
- Various ways to conserve the land
- Water supply

The specialty of Royal College emerging as the runners up in this competition is because it was able to achieve such a target while being in the commercial hub of Sri Lanka even though schools from rural districts where agriculture was the main source of income took part in this competition. Royal College agriculture society underwent stiff competition from outstation schools which have abundant space

to grow their crops while our college in the other hand was handicapped by the lack of space. Therefore it certainly is a huge achievement of the agriculture society of Royal College.



Newspapers reporting Royal win at the Inter school drama competition 2010.

# Best School in Sports

Royal College ensured there place as the 'giants' in the school sports arena when they were awarded 36 national school colours at the National School Colours night organized by the education Department. Also the most outstanding athlete and the best cricketer of the year awards were won by Charith Kapukotuwa and Bhanuka Rajapakse respectively. Royal College won many national championships during the year in various sports. Royal sportsmen represented the Sri Lankan sports team in Cricket, Baseball, Athletics, Boxing, Chess, Hockey, Rugby football, Basketball, swimming, Elle and Table Tennis.



Viduranga Bandara Wijekoon was the highest achiever in the Maths stream at the G.C.E. A/L examination 2010.

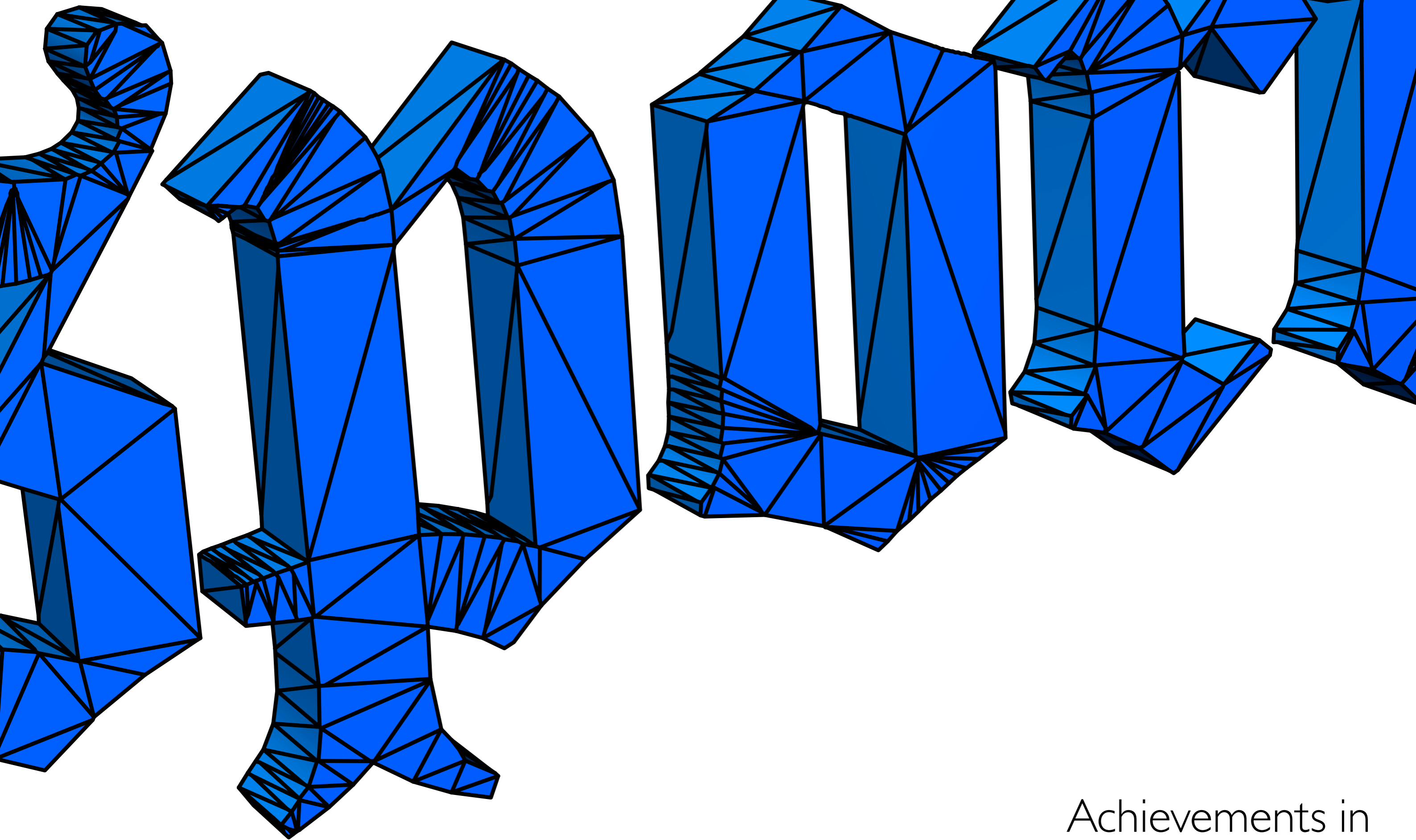

Achievements in  
Sports and Games



Royal College offers a wide range of both indoor and outdoor sports for students, including Cricket, Rugby, Rowing and Tennis. The year 2010 has been one of the most prolific years for sports in Royal College, with wins at the Bradby Shield Encounter, Mustangs Trophy, Royal-Thomian Regatta and the Royal-Thomian Basket Ball encounter. In addition to this, 21 Royalists have represented Sri Lanka at the International Level in the year of 2010.

### Athletics

- Circuit meet - Champions
- Western province athletic meet - Runners up
- Junior John Tarbet Meet - Runners up
- Relay Carnival - Runners up

### Badminton

- S. L. A. Rathnayaka Memorial Trophy All Island Inter School under 16 Super "A" division Champions.
- All Island Inter School under 19 Super "A" division 2nd Runners up.
- Runners up at the Western Province School Games.

### Basketball

- Cup 3rd place- 5'A side club tournament organized by St. Engene's Basketball club.
- 1st place- 5'A side tournament organized by Amal International School.
- Winners- Royal- Thomian annual Basketball encounter.

### Baseball

- Under 19- Runners up of the Triangular Baseball Tournament.
- Under 15- Champions of the Triangular Baseball Tournament.

### Boxing

- Winners of the Donald Obeysekera Shield
- ABA Novices Runner Up
- Western Province Boxing Meet Runner Up
- Royal-Trinity dual Boxing Meet Winner
- Junior National Runner Up

### Chess

- Super six under 20 Inter School All Island Champions
- Western Province under 19 School Games Champions
- Western Province under 15 School Games Champions



- All Island Inter School Champions under 16
- All Island Inter Schools 2nd Runners up under 20
- National School Games 2nd Runners up under 19
- National School Games 2nd Runners up under 15
- All Island Inter School 2nd Runners up under 10

### Cricket

- 35th Mustangs trophy Winners
- Under 19 one-day tournament Joint-champions

### Diving

- Sri Lanka Schools Novices Diving Championships- Champions
- Age Group Novices Diving Championships- Champions
- Sri Lanka Schools Diving Championships- Champions
- Age Group Diving Championships- Champions
- Junior National Diving Championships- Champions
- Junior National Best Diver Boys
- National Diving Championships- Champions



## Hockey

- Annual Royal-Thomian Hockey Encounter for the Orville Abenaike Memorial Trophy- Winners
- Annual Royal-Trinity Hockey Encounter for the J.C.A. Corea Cup- Winners
- Annual Royal-Kingswood Hockey Encounter for the Lennie De Silva Memorial Cup- Winners
- Annual Royal-Wesley Hockey Encounter for the Dudley K.G. De Silva Memorial Shield- Winners
- Blue & Gold Inter School U-19 All Island 7 'A' side Hockey Tournament- Champions
- U-19 Inter School Western Province Hockey Tournament- Runners Up
- 1st Royal College Hockey Team to win all 4 trophy matches in one year.
- Became champions at the Blue & Gold Hockey Tournament for the 1st time in history

## Rowing

- T. N. Fernando Memorial Trophy – Royal Thomian Regatta
- Eraj Wijesighe Trophy – Royal Thomian Regatta, 'B' Four
- Freddie Ruax Trophy – Royal Thomian Regatta, 'A' Pair
- Inaugural Trophy(Sirisena-Sirimanne Trophy) – Royal Thomian Regatta, 'A' Double Scull
- Chula Samarasinghe Challenge Trophy – Royal Thomian Regatta, 'B' Pair
- Revival Trophy(Phillip-Mohdeen Trophy) – Royal Thomian Regatta, 'B' Double Scull
- Ajith Gunawardene Challenge Trophy – Royal Thomian Regatta, 'B' Scull
- Under 19 Category Champions – Sri Lanka Rowing Nationals

## Rugby Football

- Joint Champions in the Milo Knock-Out Tournament
- Amongst the top 3 teams in the Inter School Rugby League.

## Soccer

- Zahira 7's Plate Champions, Runners Up
- All Island Division II Tournament Runners Up. Promoted to Division I
- Winners of the Annual Royal-Thomian Soccer Encounter

## Squash

- All Island Inter School Squash Championships Runners Up (Team Event)
- All Island Inter School Squash Championships Overall Champions

## Swimming

- Junior Nationals- 2nd place
- Junior Short Course Nationals- 6th place
- Senior Nationals- 3rd place
- Senior Short Course Nationals- 2nd place
- Age group championships- 4th place
- Sri Lanka Schools(Public Schools)- 2nd Place
- Royal- Thomian Annual Swimming Meet- Winners

## Table Tennis

- National School Games- Western Province- 3rd place.
- Under 19 All Island Inter School Championship
- Under 19 A Division- Runners up(Team A)
- Under 19 A Division- Semi Finalists(Team B)
- Under 19 C Division- Runners up

## Tennis

- All Island Public Schools Tennis Tournament- Overall 2nd Place, U-15 Champions, U-19 Champions
- National School Games Tennis Tournament- Champions for the 3rd consecutive year.

## Volleyball

- Under 18 DSI District Champions.
- Under 18 DSI Provincial Semi Finalists.



- Under 19 Circuit Runners up.
- Under 19 Zonal Champions.
- Under 19 Provincial 2nd Runners up.
- Under 19 All Island Semi Finalists.
- Under 20 District Champions.
- Under 20 Provincial Runners up.

### Water Polo

- Winners of National Water Polo Tournament
- Winners of the All Island Water Polo Championships
- Winners of the U-20 Knock-Out Water Polo Tournament
- Scored 36 goals against Nalanda in the Under 20 Nationals tournament while establishing a new national record.

### Wushu

- Won 2 Gold medals, 5 Silver medals, 2 Bronze medals in the All Island Schools Wushu Tournament.
- 2nd Place in the Group Event in the All Island Wushu Tournament.
- Won 1 Gold medals, 5 Silver medals and 2 bronze medals in the Western Province School's Games 2010.

### Cadet Band

- Won 1st place in Music and Drill Competition for the consecutive 3rd year.
- Won 2nd place in Directors test.
- Won 3rd place in Hut Inspection.
- Awarded the Best Western Cadet Band in the 3rd battalion.
- Won 1st place in the NCC Western Band Competition Camp.
- Winners of the All Island Inter School Air Pistol Competition
- Won the "Best Shooter" and 3rd place at the All Island Pistol Shooting competition.

### Cadet Contingent

- Runners up at the All Island Rifle and Pistol Shooting Competition.
- 3rd place in Battalion Drill Competition.
- 3rd place in Battalion Drama Competition.
- 3rd place in Battalion Hut Inspections.
- Two officers from Royal College Cadet Contingent represented College in the Assessment Camp as Under Officers. This was the first time where two Royalists had this rare opportunity since 1985.

### Scouts

- 23 Scouts were awarded President's Scouts Award which is the highest number of President's Scouts ever produced by one batch.



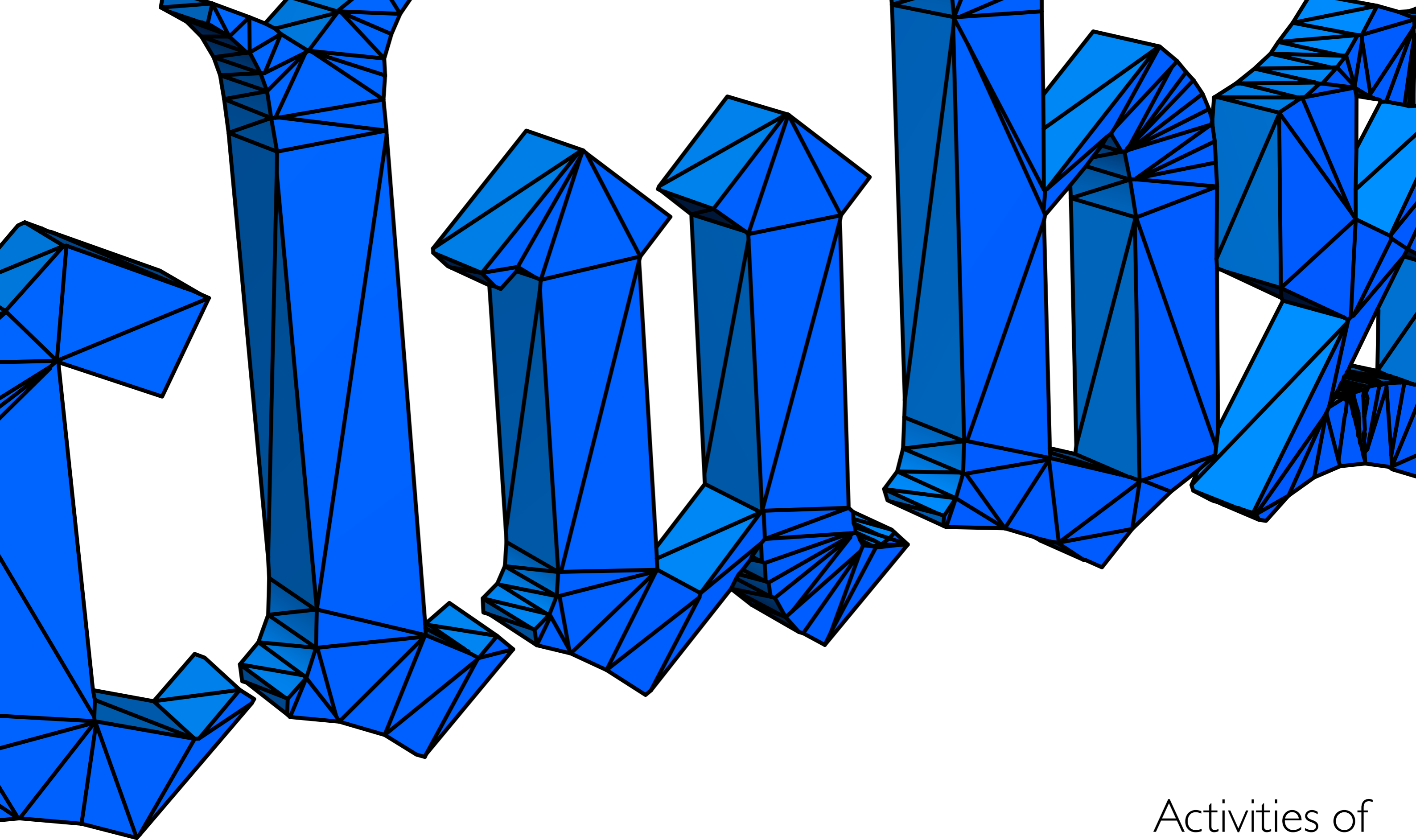

Activities of  
Clubs and Societies

Royal College has over over 50 functioning clubs and societies, which engage in projects in interschool and inner school scales. All the clubs and societies function under the two Senior Games Masters, and each club or society has it's own Master in Charge and a Student Executive Board. Every club and society is rated at the end of the year, at the Clubs and Societies Felicitation Ceremony, based on their year round performances, in to 3 grades, as A, B and C.

These student societies engage in a variety of projects which are staged in both National and International Levels. In addition, clubs and societies also involve in projects which help to improve the infrastructural, educational and spiritual development in school.

### Adventure Club

- Ballahalla Hike(February 19th)This was the first hike for the year. The main objective of this hike was to grant the new members some experience in hiking.
- Yakdesgala Hike – April 27th. This was the 2nd hike for the year 2010. The main objective was to encourage more student involvement in the clubs activities.
- Batadombalena Hike –(July 2nd)The hike was completed in 4 hours. The main objective was to give more experience to the crew in hiking and boost their confidence and self esteem.
- Balangala Hike (August 11th)We were the 1st crew to hike the mountain in less than 4 hours in known history.
- Siharaja Sinhagala Hike ( August 28th)This was the final hike of the club for the year 2010. This crew hiked a distance of more than 14 km over a period of 10 hours.

### Agriculture Society

- Due to the activities of Agriculture Society, Royal College received the 'Most Environmental Friendly School' in the Colombo District, in a competition organized by the Green Forest Association.
- Constructed a herbal garden in the school premises together with the Ministry of Indigenous Medicine.
- Conducted a Medical Clinic for the Academic and Non Academic Staff of Royal College.
- Maintained cultivation at the Mulleriyawa Mental Hospital premises in collaboration with the UNESCO club.
- Cultivated the plant 'Citronella Grass' to eradicate 'Dengue' from the school premises.

### Art Circle

- All Island Annual Art Exhibition.
- All Island Annual Art Competition.
- Decorating the school premises for Vesak Celebrations.
- Classes regarding Painting and Art held for students.
- Poster Competition for hostellers.



Awareness Projects and workshops in inner school scale, conducted for Royalists.

### Astronomical Society

- Side Walk Astronomy Night.
- 'TYMACT 10'
- Publishing the Royal Astronomer Magazine.
- Conducting an Astronomy Lecture Series for the RCAS members.
- RCAS had the privilege of conducting 'the Exploration', the Annual Astronomical Day of Sri Dharmaloka Vidyalaya.
- Field trip to Ratmalana Air Force Museum.

### Aviation Society

- Field Trip to Katunayake Air Force Camp and Bandaranayake International Airport.
- Organized a lecture conducted by Mr. Tilak Dissanayake.
- Placed 1st in the Air Traffic Control Day Quiz Competition.

### Buddhist Brotherhood

- 175th Anniversary Pirith Ceremony & Alms Giving.
- Esala Sil Programme.
- Wesak Programme.

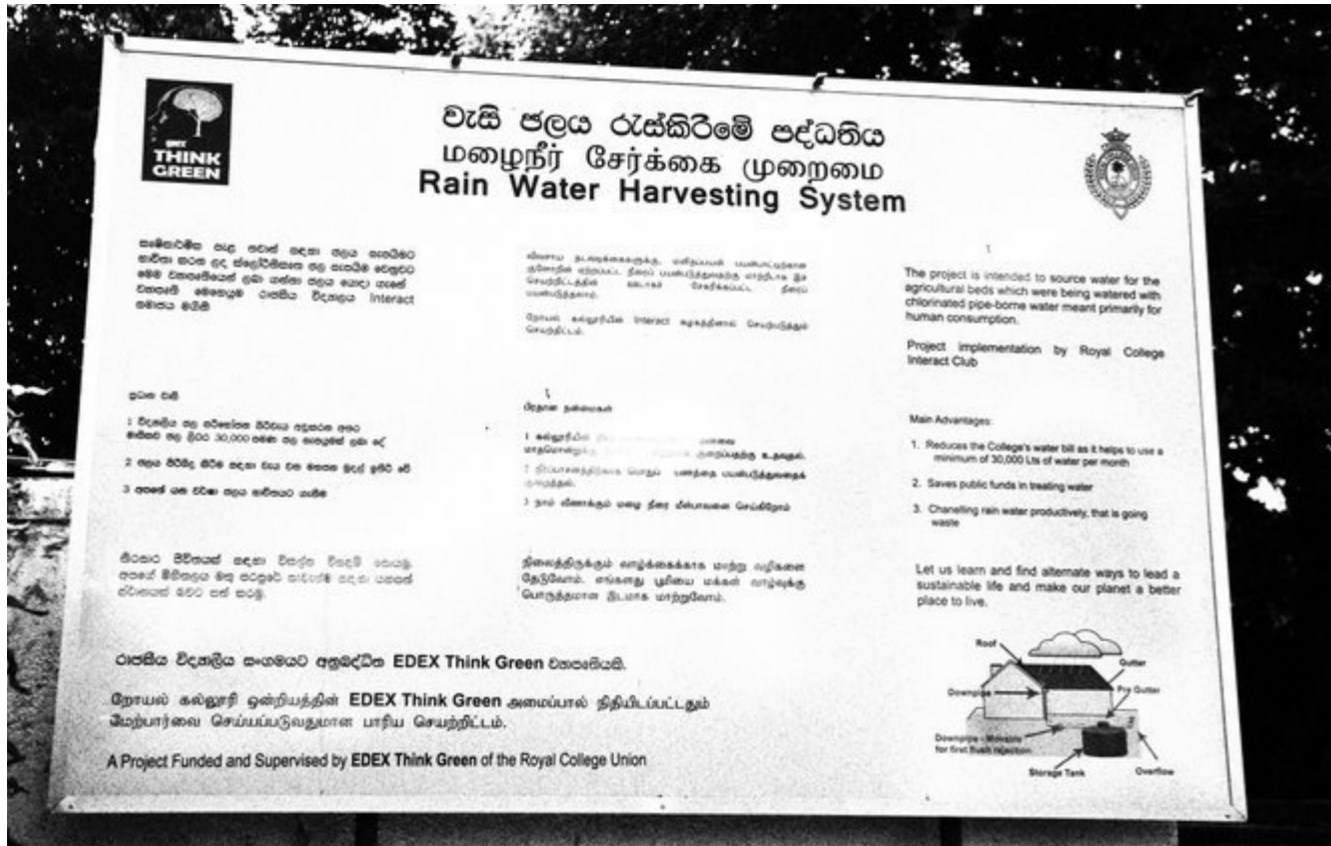

Projects which enhance the infrastructure development of the school.

- Daily Buddha Pooja Programme.
- Wesak Kalapaya.
- Monthly Pera Poya Programme.

**Catholic Students Union**

- Distribution of the 'Catholic Messenger'- The Catholic Messenger is a newspaper printed every Sunday which contains information on religious events and mass schedules. The distribution of this paper was carried out free of charge for all Catholic students in College.
- Social Service Project- The Society donated the money collected during Carol Service 2009 to a home for elders run by the church and spent the day at the church assisting them in their daily tasks.
- 175th Celebrations Thanksgiving Service

**Chemistry Club**

- The Chemistry Club was founded by Mrs. Pothupitiya with the aim of bringing the subject of Chemistry closer to science students. She was able to reach the target together with the founding members of the club. In the year 2010 we have aspired towards the same objective.

**Computer Society**

- Inter School Quiz Competition.
- Assisted College in the collection of 2500 software for the Software Competition organized by the Ministry of Education.
- Provided ICT facilities for the students from Trincomalee.

**Debators Council**

- Evening of Debates
- Inter House Debating Tournament
- Workshops for Debaters
- The A Team emerged Runners Up at the Sri Lanka All Island Debating Competition organized by Colombo Law Faculty.
- The A Team emerged Runners Up at the D.S. Senanayake 'Impromptu' Debating Competition.

**English Drama Society**

- The Inter House English Drama Competition.
- Workshops on the Technicalities of theatre.
- Workshop on Characterization in Acting.
- All Island Thepians Challenge Trophy Shakespeare Drama Competition.
- Inter School Trinity College Shakespeare Drama Competition.

**English Literary Association**

- Colombo Model United Nations- This conference was held on the 5th and 6th March at the Overseas School on Battaramulla and on the 7th March at Water's Edge Hotel. 16 delegates took part in the event, representing Royal College. It must be noted that while Viraga Perera won the award for the Best Foreign Policy Statement Council, Thamal Ellawala won the Best Delegate Award in the Economic and Social Council.
- Sri Lanka Model United Nations- This Conference was held on the 1st, 2nd and 3rd of August at the Water's Edge Hotel. This is the 3rd largest Model United Nations Conference in the world. The Royal delegation consisted of 24 students, of which a majority were freshers in the field.

**Environmental Conservation Society**

- Environment Pioneer Brigade.
- Visiting the Planetarium.
- Visiting the Zoological Museum.
- Measuring the Carbon Foote Print of Royal College.
- Beach Clean UP with EDEX Think Green.

**Film Society**

- 'Mind Your Language' seriated English Drama was shown to the Hostellers for the express purpose pf improving their command of the English Language by the special request of the Prefects.

- The film Avatar was shown as a fund raiser.
- The film Lightning Thief was shown as a fund raiser.
- The film A- Team was shown as a fund raiser.

### Gavel Club

- Developed the standard of Spoken English among the students.
- Increased the capabilities and leadership skills of the students.
- Trained them to speak in front of an audience and to help them overcome stage fear.
- To give opportunities to students to get experience and also show case their talent.

### General Knowledge Club

- Blue & Gold Quiz 2010.
- Inter Class Quiz Competition.
- Providing questions and Quiz Masters for the Annual 'Joe-Pete' Friendly Quiz 2010.
- Siyatha T20 Quiz organized by Siyatha TV – Champions.

### Hindu Students Union

- 175th Anniversary Celebration
- Kalai Mahala Vizha & 'Shiva Shakthi' book release.
- Opening of Shrine Room.
- Monthly Pooja
- Saraswathi Pooja
- Inter School Competitions.
- Inter Grade Competitions. Donating over 3000 books to students in Trincomalee and Kilinochchi.

### I EARN Society

- Teddy Bear Project.
- Heart to Heart.
- Unesco World Heritage Project.
- I'EARN Workshop.
- My Hero

### Insurance Society

- Initiated a special Insurance programme for college together with Sri Lanka Insurance PLC at reasonable rates.
- Organized an art competition in Jinarathana Childrens' Home together with the Art Circle.
- Organized an Art, Essay and poetry competition.

### Interact Club



Royal Spirit elevation projects

- Organized "Abstract" together with Bishop's College.
- Published the annual Bradby Shield Souvenir and the Royal-Thomian Regatta Souvenir.
- The book "Behind Bars" was compiled by the Fun-Duh-Mental committee.
- Organized a shramdana campaign.
- Donated brand new school items to the Omaragolla MV, Kurunagala.

### Islamic Society

- Annual Islamic Day
- Inter Grade competition
- All island inter school competitions.
- Community service project for the displaced people of the Eastern Province at the Sri Lanka Institute.
- Participated at an event to raise funds to build houses for the Navy soldiers.
- Participated at the National Colours Awarding ceremony.
- Participated at the Royal College Colours Awarding Ceremony.
- Performed acts in SAGA Concert.

### Library Readers Association

- A Book Exhibition was organized.





Entertainment and Fund Raising projects

- Organized a film week.
- Annul General Knowledge Competition was conducted.
- 'Vidarshana '10'
- Iranamdu Project.

#### Mathematics Society

- Seminar on Statistics for the 2010 A/L Batch.
- Inner School Mathematics Competition.
- Inter School Mathematics Competition.
- Selling of the Mathematics Past Papers Book.

#### Media Unit

- LE POSTRE TEAM handled publicity of many College events.
- Members of Media Unit read local, foreign and sports news daily.
- Webcast of the Rugby Season 2010 and poster campaign.

#### Oriental Music Society

- Emerged Champions in All Island Music Competitions.
- The society conducted auditions for SAGA. Conducted a seminar for A/L Oriental Music Students.
- 'SUSARA 2010'

#### Philatelic Club

- 175th Anniversary Stamp Designing Competition.
- Issuing the 175th Anniversary Stamp and the First Day Cover and Docket.
- Issuing the Stamp Collector's Item.
- Royal Philex 2010
- 24th Volume of 'The Royal Philatelist'.
- Stamp Designing Workshop for students of Royal Stamp Exchange Week

#### Photographic Society

- Lectures on photography were conducted monthly.
- Organized 5 field trips.
- Participated in photography competitions.
- Photographed all major school events.

#### Radio Club

- Provided sound equipment for major school events.
- Carried out the FM Royal Radio Programme on a large scale, in association with the Royal College Union. It was transmitted to Kandy, Galle as well as Colombo and the special webcast was set up for listeners worldwide.

#### Red Cross Society

- Annual Blood Donation Campaign.
- Rendered first aid service at the Royal-Thomian Big match.
- Rendered first aid services to the Mustangs trophy.
- Rendered first aid services to the Cycle Parade.

#### Science Association

- Conducted Lecture series for the grade 12 students in Physics and chemistry.
- Organized Quiz competitions.
- Organized Inter school Essay and Blog Competition.
- Science day was celebrated.

### Sinhala Drama Society

- Organized Practical workshops for students.
- Organized a Drama for the Colours presentation.
- Organized a Drama for the SAGA.
- Participated the competitions organized by the Ministry of Education.
- Inter School Drama Competitions were held.
- Organized 'Harasara Pranama' Drama Awards Ceremony.

### Sinhala Language and Literature Unit

- The annual language and literature competitions were conducted within the school.
- All Island Inter School language and Literature tournament was conducted.
- "Aseniya Kusuma" festival of arts was conducted.

### Sinhala Oratory and Debating Society

- The annual Royal-Thomian Big Debate was conducted.
- The biggest All island National Debating Tournament "THARKA" was organized.
- Inter House debating tournament was conducted.
- Open Discussion Programmes were held.
- 'Sampraapthi'- A debating tournament and workshop held to improve the debating skills of other schools.

### Social Services League

- Organized the annual "Wesak Dansala" held at the Kelaniya Raja Maha Viharaya.
- Fund raising projects and rural development programmes were conducted.
- Daily duties of Road Safety and Book Shop were maintained.

### Student Christian Movement

- To celebrate the birth of Jesus Christ the annual Carol Services were conducted.
- The club organized Bible studies to support and to educate the Christian students.
- Bible Study.
- Helping an orphanage.

### Tamil Dramatic Society

- Inter school competitions were held and Inter House Drama Competition was held.
- The Annual/Main event of the society "Nadaha Vizaha" was held.



Inter-school projects in Nation scale

### Tamil Karnatic Music Society

- Workshops were held to improve basic Karnatic knowledge of the students and to introduce musical instruments and songs.
- The Annual Tamil Karnatic Orchestra "Issai Vizha" was conducted.

### Young Inventors Club

- Participated in outstation competitions.
- Training programme for inventors.

### Young Zoologists Association

- Lectures were conducted on,- "Aruma puduma sathwa lokaya",Mammals,Bio diversity and, Conservation, Reptiles of Sri Lanka, Conservation of specimens, Stuffed animal bodies, Endemic birds of Sri Lanka, Evolution of Bio diversity, Common birds.
- Visited natural History Museum.
- Education trip to Pilikuththuwa forest reservation.

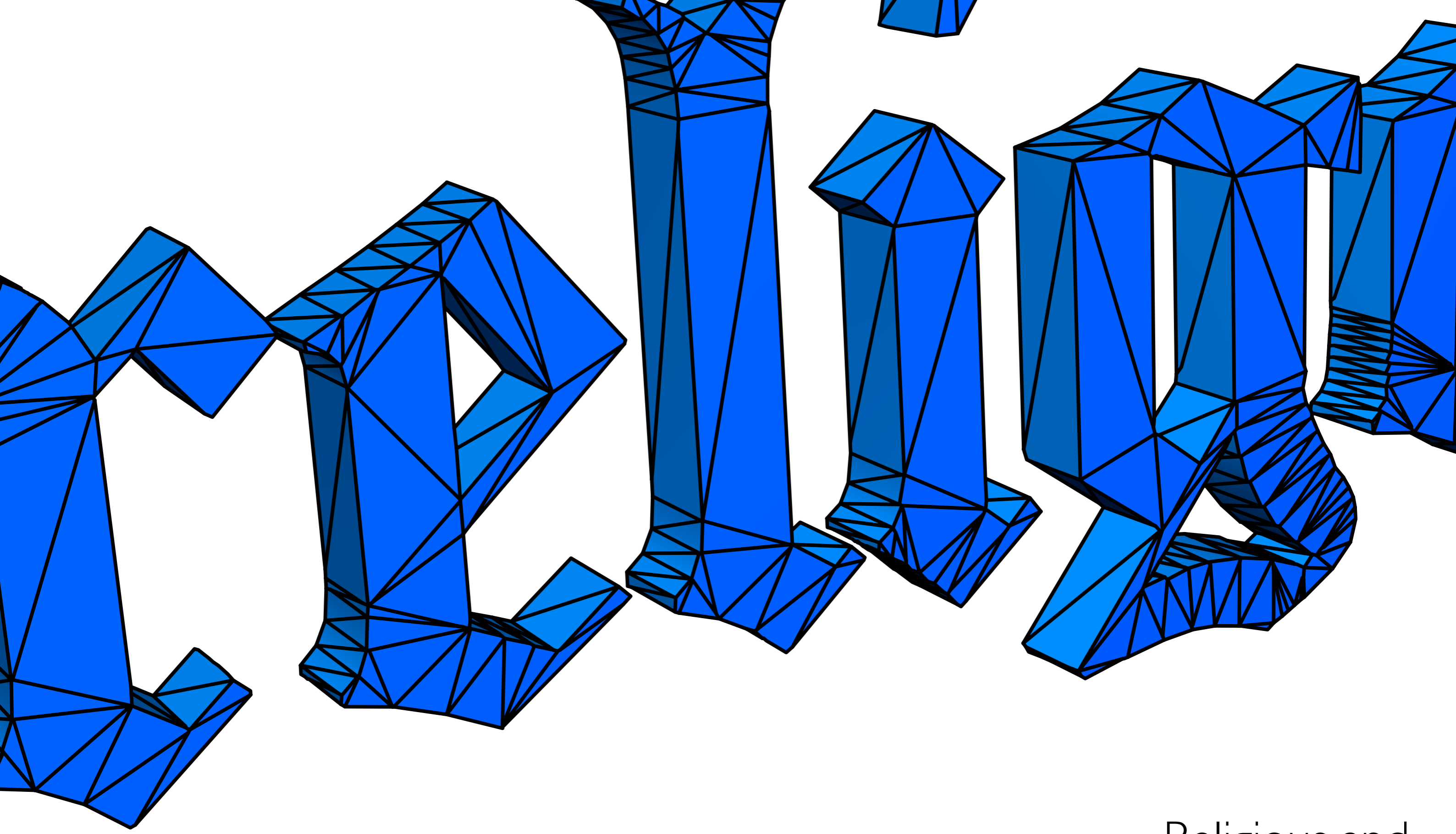

Religious and  
Cultural Activities

# 175th Anniversary Celebrations

Royal College is a renowned institution for its multi ethnic student community working in collaboration without any racial, religious, ethnic or cultural differences. A simple example for this extra ordinary setup of Royal College is the reading of lines taken from scripts representing each of the four religions before the start of any school event.

In 2010, as a part of the 175th anniversary celebrations, for simultaneous religious programmes were conducted in the school, a Sarvarathri Pirith Sajjanawa at the College Main Hall, a Catholic Mass at the Navarangahala, Hindu Blessing Ceremony and Perahera from the Kathiresan Kovil in Bambalapitiya and a special prayer programme at the Dewatagaha Mosque.

In addition to these special events, the annual religious conducts such as the Vesak Sil Programme, the Carol Service, the Islamic Day and the Hindu Cultural Day “Kallai Vizha” was also held in the year 2010, organized by the Buddhist Brotherhood, Christian Student Movement, the Islamic Society and the Tamil Literary Association, respectively.



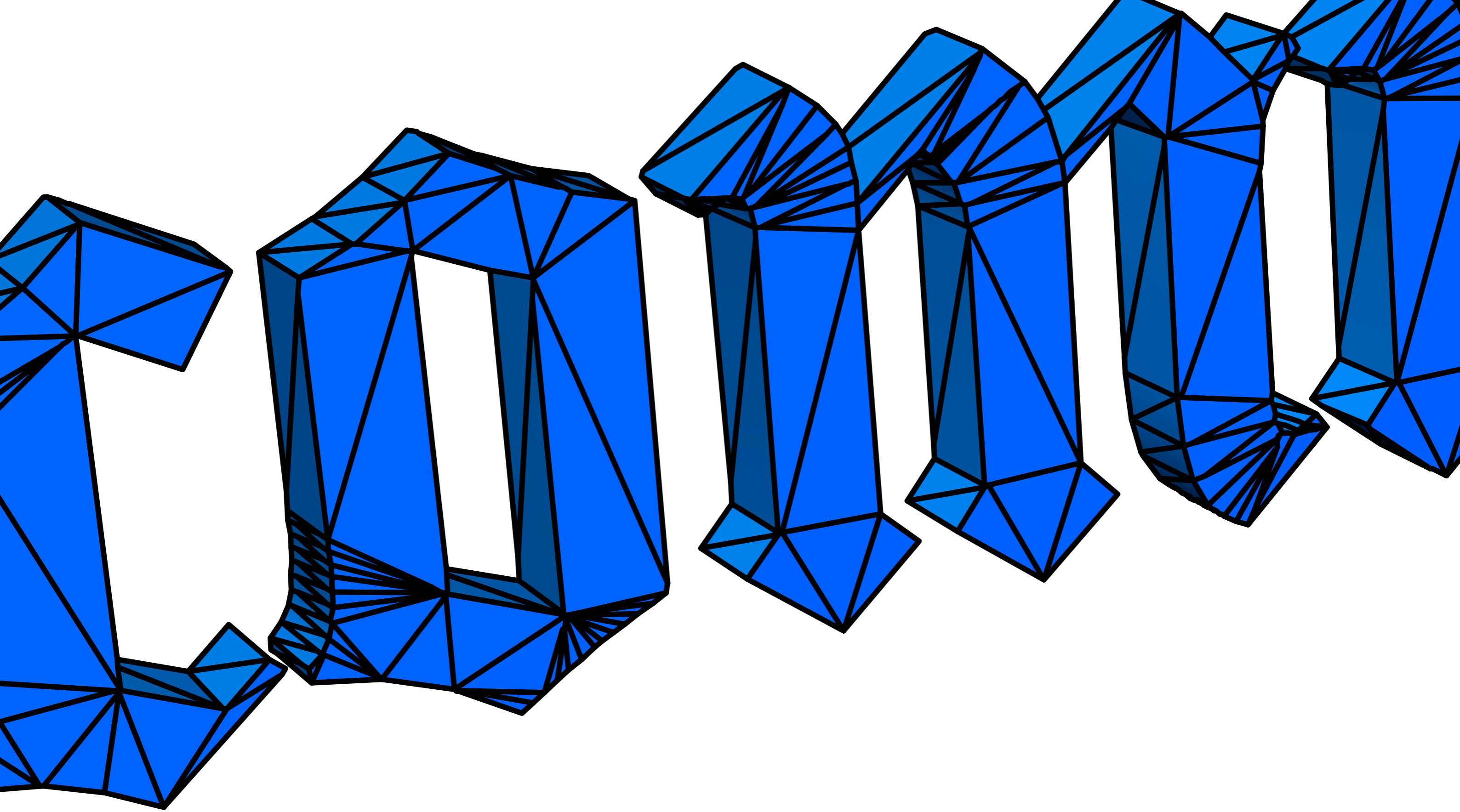

Community Service  
Projects

# Water supply project at Boossa Maha Vidyalaya, Galle

Boossa Maha Vidyalaya, Galle is a rural school for primary and secondary education in Galle, who were in need for water development system for their school agricultural garden. Even with issues of such, they had shown their enthusiasm in the field of agriculture, by winning divisional level titles in agricultural competitions. Royal College, being the front runner of the field of school agriculture, stepped up to help this underprivileged school by providing them with a fully functional water distribution scheme, where their gardens and lawns would receive a positive output.



# Water supply project at Kottawa Junior School, Galle

Being another underprivileged school The Kottawa Junior School in Galle were not fortunate enough to satisfy their basic requirement of drinking water supply. Although the school is spanned over an area of 15 acres, there was only one well and did not have a proper water management system for the use of students and the staff. Royal College took the initiative to facilitate them with required standards of pipelines and the water pressure in order to supply water for the whole school. "All these projects were done by the Royal college students on their own. All the technical and other work such as connecting pipe lines, installing the water pump etc. were also done by the students by them self"



# Mental Hospital rehabilitation project

Royal College took the initiative to go beyond the orthodox community service projects to serve our unfortunate brothers and sisters of The Mulleriyawa Mental Hospital who were in dire need of help because they were facing financial issues to initiate their home gardens. This project was primarily carried out as the inmates at the hospital were subjects to low quality food and undernourished meals and more importantly as a rehabilitation activity for the inmates.

Royal College took the initiative to bolster the Hospital to achieve better nutrition standards while providing the inmates with an outdoor activity.

Royal college successfully completed this project amidst many praise in collaboration with Jinasena Ltd.



# Participation in Development Projects in IDP Camps



Royal College was one of the first schools to initiate development projects in IDP camps in the North and East. Due to the lack of education and infrastructure facilities for the inhabitants of these IDP camps, Royal College took initiative to provide educational material, tutors for A/L and O/L students. Stationary items worth of Rs. 0.4 million were distributed in these areas for all current students living in IDP camps. Royal College also provided 150 solar lamps worth Rs. 2 million to families in IDP camps as a solution for the limited electricity facilities received by them.



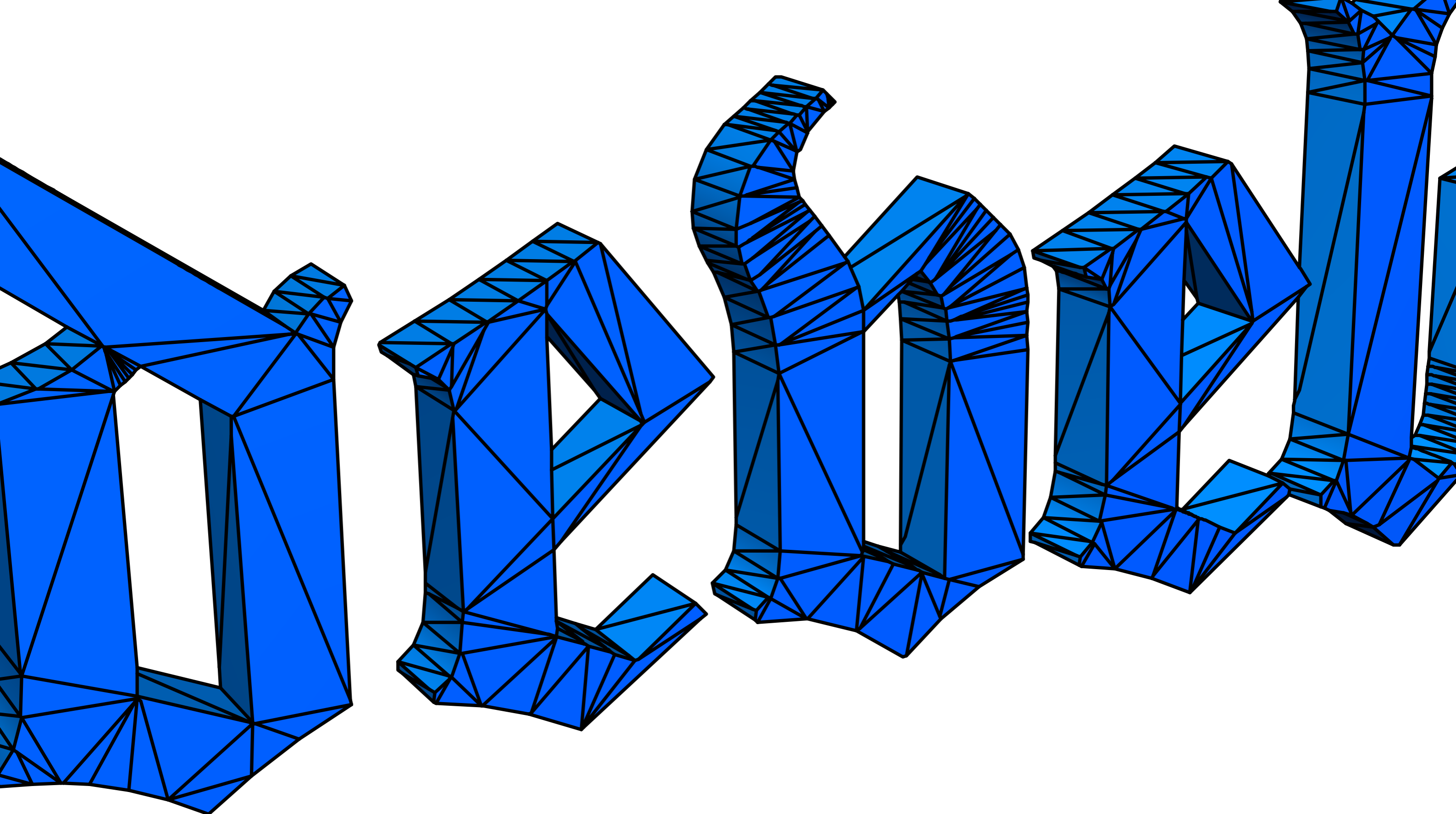

Development  
Projects



## New scoreboard for the Junior grounds

The Royal College junior ground is mainly used by u-13 and u-15 cricket teams for their training sessions, inter house and interschool matches etc. The scoreboard ground had was old, not a detailed scoreboard and also was not in a proper standard to use. Due to these issues the host had to face much difficulty when scoring during matches held at the grounds.

A new modern detailed scoreboard was built and opened at the junior grounds to facilitate the matches being played at the grounds. It is relatively a bigger scoreboard which can include all the statistics needed to be shown on a standard scoreboard.



## Carpeting the roads within the school premises

The school has around 300 teachers and considerable number of them drives their vehicles in to the school premises. Also the college host many national and interschool events at the college main hall, Navarangala, play grounds etc. it is essential to have the roads within the school premises in good condition since vehicles and people uses it on daily basis. Even though the roads within the school premises were in a satisfactory level it was fully carpeted and had been brought in to excellent conditions to use.



## Renovating the Basketball courts

Royal College provides facilities for Basketball which is one of the most popular sports in the college. Two courts which were in use were built years back and needed a refurbishment and only one of the two courts had flood-lit facility, neither it was in a proper standard to use since they were old.

After taking all these in to consideration the college re constructed both Basketball courts which include modern flood-lit facilities also with a new scoreboard and a pavilion.



## Locating new dustbins around the college premises

Dumping garbage has become a major problem in the modern world. Royal College has overcome this problem by innovating a new dustbin where litter would not fall off and also easy to use which encourages students to put their litter in to a dustbin. It is also clearly labeled and anyone who would see it can identify the particular bin where the litter should be put in to. The school also has a waste recycling plant within the school premises.



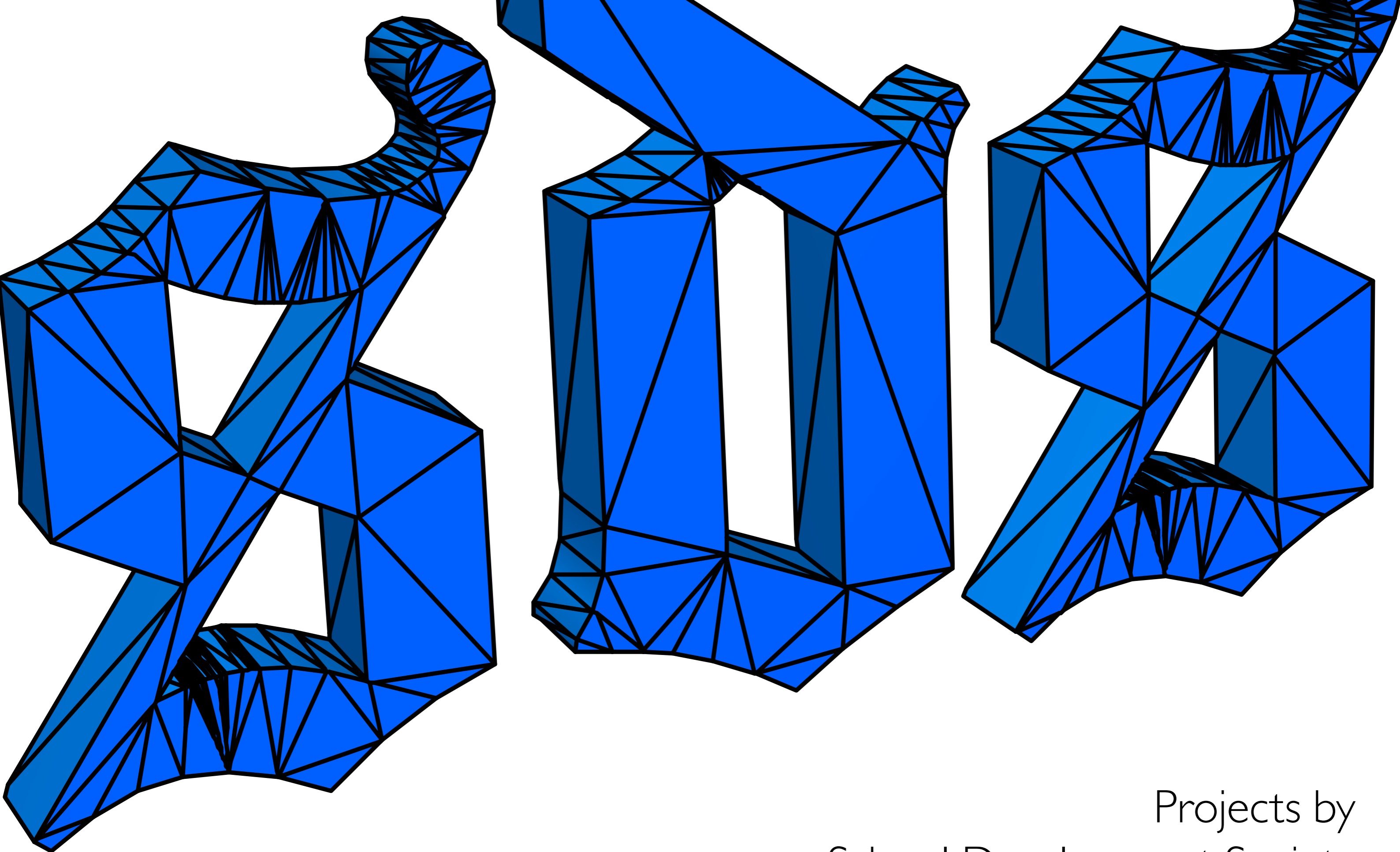

Projects by  
School Development Society

# SaGa Musical Extravaganza

The musical legend of East and West – SaGa is the “Mega Star” of Royalists and it is the most innovative and groundbreaking design and a significant milestone as an assortment musical extravaganza in the unblemished history of the ‘Alma Mater’. Music, Drama, Dancing, Singing, have been an integral part of co-curricular activities thus building self-discipline, emotional balance and sensitivity as part of holistic education articulated by the new reforms in education.

This event has proceeded to become the main fund raiser of the School Development Society, an institution that has played a key role in shaping Royal College in to what it is today, a school that is unparalleled in its provision of facilities and opportunities to its student community. The significance of the event is doubled as it provides ample opportunities for students to further attune their skills and talent and prove to the outside world their abilities.



# Modern Cafeteria



Canteen is one of the important places in any school where a large number of students use it at once and for the same purpose that is to consume food and beverages for their daily meals. Since there are so many events held at the college the main canteen is been used more often.

For this reason the old canteen was refurbished and brought up to a modern style canteen which provides self service, fans, modern lighting, Television and a dining area where over hundred students can use it at once.



# Renovation of Lavatories into Hygienic Toilets

The School Development Society has initiated in renovation of the Student and Visitors toilets in the Main Section, upgrading them in to hygienic toilets with modern sanitation facilities, which allow students and visitors to use these washrooms hassle free.



# Repairing the College walls and gates

In 2010, the School Development Society successfully completed repairing the brick wall that runs from Rajakeeya Mawatha to Reid Avenue, reinforcing it with new bricks, a mesh fence and a new coating of paint. Simultaneously, The Boake Gate and the Junior Gate were also repainted, with the Primary school gate being rebuilt as a model of the traditional Boake gate.



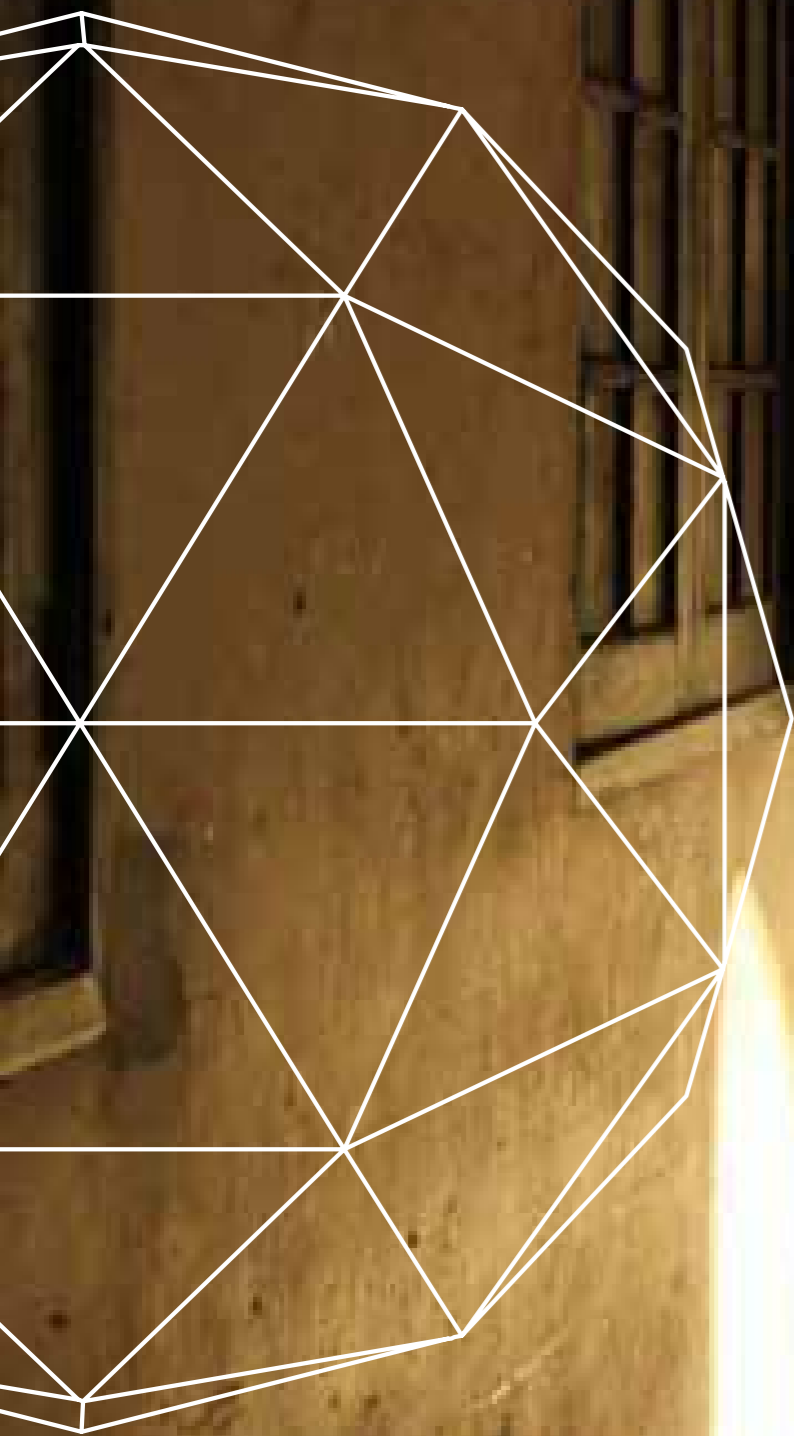

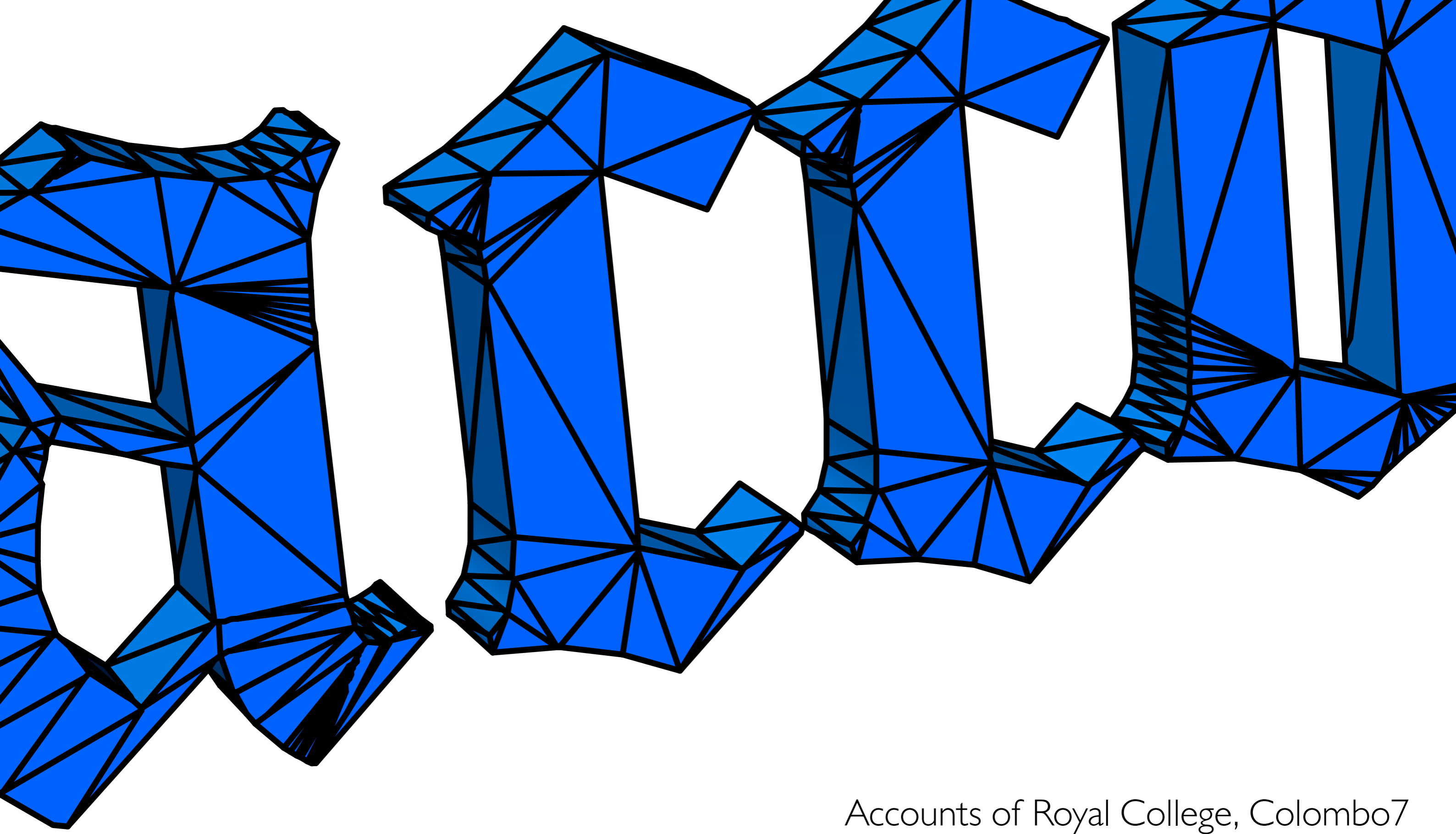

Accounts of Royal College, Colombo7  
School Development Society  
for the Year ended 31st December 2010

# School Development Society

Royal College School Development Society carries out wide range of activities such as giving finance assistance under the college principal, organizing fund raisers etc. SAGA musical extravaganza is one of the biggest revenue sources to the society. The society employs about 36 academic staff and around 60 non-academic staff. This is one of the great services done by the society towards the school's betterment. Also it provides counseling for back-ward students to bring them forward and assists financially for sportsmen who compete nationally and internationally. Welfare activities of students and society employees are also undertaken by the society.

The SDS of Royal College is the nucleus of the school which is responsible of producing good loyal, well disciplined proud citizens to our motherland.

Members of the SDS, parents work deliberately on all the projects and services carried out by the society to make it a success. They are the back bone of the School Development Society.

**Pathmaperuma, Muthugala & Co. — Chartered Accountants**  
No. 132, REID AVENUE, COLOMBO – 04 – SRI LANKA.  
Tel – 011- 2582946, Fax – 011- 2593174, e-mail – muthugala\_company@yahoo.com

## Auditor's Report To the members of Royal College School Development Society

We have examined the Balance Sheet of Royal College School Development Society for the year ended 31<sup>st</sup> December, 2010 and the related Income and Expenditure Account, Cash Flow Statement, Fund Movement Analysis together with Notes on Accounts appear from page 01 to 21.

### Committee's Responsibility for the Financial Statements

The Executive Committee managing the Society is responsible for the preparation and fair presentation of these financial statements which includes designing, implementing and maintaining Internal Controls relevant to the preparation and fair presentation of financial statements that are free from material misstatement.

### Scope of Audit and Basis of Opinion

Our responsibility is to express an opinion on these financial statements based on our audit. We conducted our audit in accordance with Sri Lanka Auditing Standards which require that we plan and perform the audit to obtain reasonable assurance whether the financial statements are free from material misstatement.

Our Audit includes examining on a test basis, evidence supporting the amounts and disclosures in the financial statements as well as evaluating the overall financial statement presentation.

We have obtained reasonable information and explanation which to the best of our knowledge and belief were necessary for the purpose of the audit to form our opinion.

### Opinion

In our opinion, so far as appears from our examination, the society maintained proper books of account and records for the year ended 31<sup>st</sup> December, 2010 and the financial statements give a true and fair view of the society's state of affairs as at 31<sup>st</sup> December, 2010 and excess of expenditure over income for the year then ended.



22<sup>nd</sup> March, 2010  
Colombo.

PATHMAPERUMA MUTHUGALA & CO  
CHARTERED ACCOUNTANTS

**Royal College School Development Society**

**Balance Sheet as at 31st December, 2010**

2009	Assets	Note	
<b>Non Current Assets</b>			
6,090,490	Property, Plant & Equipment	1	8,458,300.16
<b>Current Assets</b>			
496,212	Inventories		496,991.66
211,890	Loans & Advances	2	137,800.00
88,243	Receivables	3	428,243.30
20,400	Cash and Cash Equivalents	4	395,204.46
816,745			1,458,239.42
6,907,235	Total Assets		9,916,539.58
<b>Funds &amp; Liabilities</b>			
<b>Funds</b>			
(5,226,719)	Accumulated Fund	5	(5,937,960.28)
5,230,499	Other Funds	6	13,089,342.99
3,780			7,151,382.71
<b>Current Liabilities</b>			
-	Refundable Deposits	7	250,000.00
305,932	Creditors - Book shop	8	263,755.70
3,651,215	Accrued Expenses	9	2,251,401.17
2,946,309	Bank Overdraft	10	-
6,903,455			2,765,156.87
6,907,235	Total Funds & Liabilities		9,916,539.58

Signed on behalf of Royal College School Development Society

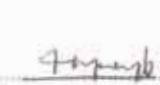
  
President

  
Treasurer

  
Secretary

(1)



**Royal College School Development Society**  
Income & Expenditure Account For the  
Year Ended 31st December, 2010.

2009	Income	Note	
28,476	New Membership Fees		28,776.00
1,005	Telephone Call Income		-
14,350	Vehicle Hire Income		56,350.00
1,807,395	Rent Income	11	1,849,591.11
3,996,557	Donations	12	9,004,500.00
1,017,319	Ministry of Education	13	619,425.00
2,033,026	Zonal Education	14	49,148.38
58,308	Abroad Leave School Fees		-
(49,550)	Minikata Magazine		-
5,000	Royal Magazine		200,000.00
200,000	Soft Drinks Contract Income		900,000.00
(1,683,266)	SAGA VI Income	15	4,142,611.28
-	Insurance Claim		86,200.00
35,537	SDS Book Shop Income	16	946,272.79
1,293,140	Interest Income		493,241.49
1,162	Library Fines		1,676.75
77,150	Fines for Lost Items	17	168,150.00
418,515	Sale of Exam Papers		430,304.00
535	Duplo Income		-
41,000	Non Refundable Tender Deposit		160,000.00
-	Festival Income	18	155,500.00
258,841	Other Income	19	17,366.00
			19,309,112.80
9,554,499			

**Expenditure**

35,650	Audit Fees		-
1,380,234	Travelling & Transport	20	1,420,946.87
-	Vehicle Insurance & Registration	21	217,623.27
1,612,582	Vehicle Repairs & Maintenance	22	1,340,119.34
121,994	Agriculture Unit	23	34,120.20
397,967	Bank Charges		61,189.10
70,005	Debit Tax		72,506.39
21,057	Overdraft Interest		3,826.03
86,487	Education Expenses	24	213,637.00
-	Exam Expenses	25	641,994.00
-	Festival Expenses	26	802,113.00



Royal College School Development Society  
Notes on Accounts For the Year Ended 31st December,2010.

784,200	War Memorial Ceremony	-	
578,565	Food Expenses	497,677.00	
214,400	Expenses on Gifts	32,590.00	
67,193	Contribution to E.P.F.	75,716.35	
16,798	Contribution to E.T.F	15,911.25	
245,448	Incentives & Allowances	36,757.22	
3,798,872	Salaries-Academic Staff	4,542,927.20	
-	Salaries -Staff Group A	1,321,957.65	
236,154	- Do - -Staff Group A I	607,006.36	
1,029,299	- Do - -Staff Group B	1,101,876.99	
150,517	- Do - -Staff Group c	2,623,321.38	
788,130	Overtime	845,862.67	
386,900	Telephone Bills-Land Phones	380,172.92	
69,756	-Mobile Phones	46,435.85	
124,600	Royal Magazine	98,000.00	
10,000	Exhibition Expenses	-	
67,665	Hiring Equipment	40,886.50	
20,935	Staff Welfare	53,873.00	
(509,075)	Band Fiesta Expenses	27 355,854.50	
669,515	Office Equipment Maintenance	697,253.72	
1,040,005	Prize Giving	-	
91,725	Debating Team Expenses	-	
43,019	Building Maintenance	-	
190,984	Sundry Expenses	165,381.79	
97,498	Postage & Delivery	50,728.00	
440,540	Colours Night	579,241.40	
361,980	Sports Meet	28 1,202,666.20	
350	Stamp Duty	-	
1,437	ETF Surcharge	-	
-	EPF Surcharge	9,155.00	
19,530	Dengue Prevention Expenses	-	
-	Advertising	31,449.60	
-	175th Anniversary Celebration Expenses	29 39,529.80	
231,013	Band Expenses	30 259,946.50	
(14,993,930)		(20,520,254.05)	
(5,439,431)	Excess of Expenditure Over Income	(1,211,141.25)	

**Note 1**

**Property, Plant & Equipment**

Description of Asset Cost	On 01/01/2010	Additions during the year	Disposals	as at 31/12/2010
Office Equipment	5,660,581.66	190,890.00	-	5,851,471.66
Machinery	58,522.00	-	-	58,522.00
Computers & Equipments	-	850,000.00	-	850,000.00
Building Equipment	343,536.50	-	-	343,536.50
Other Equipment	27,850.00	-	-	27,850.00
Furniture	-	1,326,920.00	-	1,326,920.00
	6,090,490.16	2,367,810.00	-	8,458,300.16

\* Depreciation has not been provided on the above assets.

**Note 2**

**Loans & Advances**

21,200	Festival Advances	22,200.00
33,500	Other Loans	103,000.00
12,600	RTM Festival Advance	12,600.00
144,590	Advance Payments	-
211,890		137,800.00

**Note 3**

**Receivables**

88,243	Refundable Deposit (Note 3.1)	133,243.30
-	SAGA VI Income Recievable	295,000.00
88,243		428,243.30

Note 3.1 Refundable Deposit		
55,000	Filling Station	100,000.00
12,750	Electricity Deposit	12,750.00
10,000	For Gas Cylinders	10,000.00
10,493	Provincial Engineer	10,493.30
88,243		133,243.30

Note 4 Cash and Cash Equivalents		
18,400	Cash in Hand	43,914.99
2,000	Petty Cash	2,000.00
-	Current A/C - People's Bank A/C No.086100150005399	349,289.47
20,400		395,204.46

Note 5 Accumulated Fund		
	Balance on 1/1/10	(5,226,719.03)
	Excess of Expenditure Over Income	(1,211,141.25)
	Prior Years Adjustments (Note 5.1)	499,900.00
	Balance on 31/12/10	(5,937,960.28)

Note 5.1 Prior Year Adjustments		
	Refundable Deposit - Filling Station	45,000.00
	SAGA V Sponsorship	500,000.00
	SAGA V Strip Advertisement	3,000.00
	War Memorial Ceremony	(4,800.00)
	Prize Giving	(43,300.00)
		499,900.00

Note 6 Other Funds		
395,367	Security Fund	(40,248.18)
1,377,892	Building Maintenance Fund	2,026,910.41
(6,679,733)	Sports Fund	(6,445,819.79)
(871,286)	Stationery Fund	(1,465,314.85)
8,119,705	Library Fund	9,971,853.49
2,786,901	Technological Studies Fund	3,887,671.28
(878,795)	Sanitary Fund	707,108.28
789,892	Electricity Fund	5,267,865.80
(1,192,272)	Lab Equipment Fund	(1,112,586.93)

936,942	Clubs & Societies Fund	(338,981.97)
445,885	Security Deposit - Canteen & other Funds	630,885.45
5,230,499		13,089,342.99

Note 7 Refundable Deposits		
-	Main Canteen	150,000.00
-	Milk Bar	100,000.00
-		250,000.00

Note 8 Bookshop Creditors		
84,530	Leader Stationers	94,497.00
209,076	Panther Enterprises	137,167.50
3,750	Kinyo Traders (PVT) LTD	-
4,826	Beepee Enterprises	4,802.00
3,750	Mihiri Publishers	-
-	Superior Enterprises	11,554.20
-	Mr. D.M.K. Dissanayake	15,735.00
305,932		263,755.70

Note 9 Accrued Expenses		
277,165	Salaries - Coaches	312,500.00
358,208	-Non Academic Staff	1,339.00
365,136	-Teachers	10,000.00
74,067	Electricity - Main Building	-
59,409	-New Computer Lab	-
59,967	-New Hostel	-
59,667	-Nawaragahala	-
130,985	-Others	-
28,243	Incentives & Allowances	5,000.00
60,871	Overtime	48,100.84
969,293	Secure Security Services	592,366.67
34,432	Withholding Tax	96,222.41
50,950	Fuel	66,346.75
41,507	Stationery	131,186.96
174,039	Printing - Exam Papers	-
-	-Other	84,526.08
67,705	Telephone- Land Phones	28,095.68
15,902	Mobile Phones	5,290.56
9,160	EPF	10,610.00

1,374	ETF	1,591.50
278,290	Vehicle - Repairs	-
77,037	- Do - - Services	-
1,905	- Do - - Others	-
19,140	Building Maintenance	22,000.00
8,000	Clubs & Societies -Commerce Society	9,600.00
4,636	School Maintenance	36,488.00
-	Sports- Elle	-
1,800	-Hockey	-
12,325	-Swimming	-
10,000	-Water Polo	-
37,000	-Cadet Platoon	-
42,925	-Badminton	-
10,080	-Volley Ball	-
14,500	-Chess	-
23,200	-Equipment	-
2,130	-Other	-
-	-Primary Sports Meet	5,000.00
36,351	Food	5,243.00
143,720	Toilet Cleaning	-
300	Travelling	-
-	Audit Fees	58,650.00
-	SAGA VI Printing	127,500.00
-	SAGA VI Entertainment	170,433.72
-	SAGA VI Carnival	45,000.00
-	SAGA VI Other	3,500.00
-	Band Fiesta Expenses	183,440.00
-	Festival - Bhakthi Gee	41,000.00
-	Education Expenses	13,940.00
-	Exam Hall Arrangement Expenses	10,400.00
-	Library - News Papers	9,110.00
-	Technological Expenses	80,195.00
-	Piano Distribution Expenses	36,725.00
<u>3,561,418</u>		<u>2,251,401.17</u>

**Note 10**  
**Bank Overdraft**

2,946,309 Bank Of Ceylon- Kollupitiya Branch A/C No.0001630346

-

**Note 11**  
**Rent Income**

Exam Hall	800,065.00	
Exam Hall Arrangement Expenses	(247,973.89)	552,091.11
Main Canteen		624,400.00
Main Hall		15,000.00
Milk Bar		658,100.00
		<u>1,849,591.11</u>

**Note 12**  
**Donations Received**

A/L Commerce	2,531,000.00
A/L Maths	4,287,000.00
Royal College Union Trust	100,000.00
Wijayanayake Scholarship	45,000.00
Others	2,041,500.00
	<u>9,004,500.00</u>

**Note 13**  
**Ministry of Education**

Ministry of Education	410,300.00
Piano Distribution Reimbursement	209,125.00
	<u>619,425.00</u>

**Note 14**  
**Zonal Education**

Telephone Reimbursement	38,848.38
Quality Input	10,300.00
	<u>49,148.38</u>

**Note 15**  
**SAGA VI Income**

Sale of Tickets	1,115,000.00
Donations	51,200.00
Carnival	265,000.00
Souvenir & Advertisements	
Inner Page Strips	4,137,250.00
Inner Cover Page Strips	635,000.00
Back Page Strips	610,000.00
Full Page Strips	75,000.00
Sponsorships	50,000.00
Banners	320,000.00
	<u>6,122,250.00</u>
	<u>7,553,450.00</u>

Expenses		
Costumes	22,500.00	
Lights & Sounds	2,008,000.00	
Entertainment	170,433.72	
Printing	227,500.00	
Others	775,975.00	
Carnival Expenses	206,430.00	(3,410,838.72)
		<u>4,142,611.28</u>

**Note 16**  
**SDS Book Shop Income**

Book Shop Sales		1,669,980.00
Opening Stock	496,212.00	
Book Shop Purchases	724,486.87	
	<u>1,220,698.87</u>	
Closing Stock	(496,991.66)	(723,707.21)
		<u>946,272.79</u>

**Note 17**  
**Fines for Lost Items**

Lost Student's Record Books (SRB)		20,000.00
Lost Student ID Cards		148,000.00
Lost Visitors Pass		150.00
		<u>168,150.00</u>

**Note 18**  
**Festival Income**

Bhakthigeetha		100,500.00
English Day		55,000.00
		<u>155,500.00</u>

**Note 19**  
**Other Income**

Envelopes		5,175.00
Letterheads		375.00
Other Income		11,816.00
		<u>17,366.00</u>

**Note 20**  
**Travelling & Transport**

Fuel		1,292,576.87
Oil		930.00
Travelling		127,440.00
		<u>1,420,946.87</u>

**Note 21**  
**Vehicle Insurance & Registration**

Insurance		
60-4902	37,488.26	
NA-6078	102,585.59	
TJ-9618	5,156.01	
GD- 9250	58,770.41	204,000.27
		<u>204,000.27</u>
Registration		
63-1038	12,200.00	
60-4902	1,423.00	13,623.00
		<u>13,623.00</u>
		<u>217,623.27</u>

**Note 22**  
**Vehicle Repairs & Maintenance**

Repairs		1,154,181.54
Services		77,661.00
Tyres		108,276.80
		<u>1,340,119.34</u>

**Note 23**  
**Agriculture Unit**

Agriculture Unit Income		15,095.00
Agriculture Unit Expenses		(49,215.20)
		<u>(34,120.20)</u>

**Note 24**  
**Education Expenses**

Education Expenses		164,188.00
Prefect Badges		49,449.00
		<u>213,637.00</u>

**Note 25**  
**Exam Expenses**

Arrangements		72,400.00
Translating		7,500.00
Type Setting		562,094.00
		<u>641,994.00</u>

**Note 26**  
**Festival Expenses**

Bhakthi Geetha		118,200.00
English Day		50,000.00

**Royal College School Development Society**  
Funds Movement Analysis for the  
Year Ended 31st December,2010

Children's Day	10,000.00
Grade I Concert	49,500.00
Sil Programme	51,700.00
Teachers' Day	135,990.00
Piano Distribution	274,855.00
Others	111,868.00
	<u>802,113.00</u>

**Note 27**

**Band Fiesta**

Band Fiesta Income		
Eastern Band	42,000.00	
Eastern Orchestra	54,000.00	
Western Band	94,500.00	
Percussion Band	51,000.00	
Western Orchestra	72,000.00	
Sponsorships	146,000.00	459,500.00

Band Fiesta Expenses	(815,354.50)
	<u>(355,854.50)</u>

**Note 28**

**Sports Meet**

Primary Sports Meet	671,700.20
College Sports Meet	530,966.00
	<u>1,202,666.20</u>

**Note 29**

**175th Anniversary**

175th Anniversary Income	190,300.00
175th Anniversary Expenses	(229,829.80)
	<u>(39,529.80)</u>

**Note 30**

**Band Expenses**

Cadet Band	211,946.50
Western Band	48,000.00
	<u>259,946.50</u>

**Security Fund**

Balance on 1/1/10	395,366.65
Additions During the Year	6,248,760.00
Less: Expenses	(6,684,374.83)
Balance on 31/12/10	<u>(40,248.18)</u>

**Building Maintenance Fund**

Balance on 1/1/10	1,377,891.97
Additions During the Year	2,758,540.00
Less: Expenses	(2,109,521.56)
Balance on 31/12/10	<u>2,026,910.41</u>

**Sports Fund**

Balance on 1/1/10	(6,679,732.85)
Additions During the Year	6,941,100.00
Less: Expenses	(6,707,186.94)
Balance on 31/12/10	<u>(6,445,819.79)</u>

**Stationery Fund**

Balance on 1/1/10	(871,285.65)
Additions During the Year	4,909,740.00
Less: Expenses	(5,503,769.20)
Balance on 31/12/10	<u>(1,465,314.85)</u>

**Library Fund**

Balance on 1/1/10	8,119,704.59
Additions During the Year	2,231,700.00
Less: Expenses	(379,551.10)
Balance on 31/12/10	<u>9,971,853.49</u>

**Technological Studies Fund**

Balance on 1/1/10	2,786,901.31
Additions During the Year	3,570,720.00
Less: Expenses	(2,469,950.03)
Balance on 31/12/10	<u>3,887,671.28</u>

**Sanitary Fund**

Balance on 1/1/10	(878,794.84)
-------------------	--------------

Additions During the Year	2,678,040.00
Less: Expenses	(1,092,136.88)
Balance on 31/12/10	<u>707,108.28</u>

#### Electricity Fund

Balance on 1/1/10	789,892.42
Additions During the Year	7,982,887.31
Less: Expenses	(3,504,913.93)
Balance on 31/12/10	<u>5,267,865.80</u>

#### Lab Equipment Fund

Balance on 1/1/10	(1,192,271.93)
Additions During the Year	560,400.00
Less: Expenses	(480,715.00)
Balance on 31/12/10	<u>(1,112,586.93)</u>

#### Club & Societies Fund

Balance on 1/1/10	936,941.63
Additions During the Year	1,272,380.00
Less: Expenses	(2,548,303.60)
Balance on 31/12/10	<u>(338,981.97)</u>

#### Security Deposit Canteen & other Fund

Balance on 1/1/10	445,885.45
Additions During the Year	185,000.00
Less: Expenses	-
Balance on 31/12/10	<u>630,885.45</u>

## Funds Movement Analysis

### Additions to the Funds

#### Security Fund

School Fees	<u>6,248,760.00</u>
-------------	---------------------

#### Building Maintenance Fund

School Fees	2,678,040.00
Income	80,500.00
	<u>2,758,540.00</u>

#### Sports Fund

School Fees	4,913,940.00
Ministry of Education	36,000.00
Income	1,991,160.00
	<u>6,941,100.00</u>

#### Stationery Fund

School Fees	4,909,740.00
-------------	--------------

#### Library Fund

School Fees	<u>2,231,700.00</u>
-------------	---------------------

#### Technological Studies Fund

School Fees	<u>3,570,720.00</u>
-------------	---------------------

#### Sanitary Fund

School Fees	<u>2,678,040.00</u>
-------------	---------------------

#### Electricity Fund

School Fees	4,017,060.00
Ministry of Education	1,888,790.95
Zonal Education	2,077,036.36
	<u>7,982,887.31</u>

#### Lab Equipment Fund

School Fees	<u>560,400.00</u>
-------------	-------------------

#### Club & Societies Fund

English Drama	15,000.00
Art Circle	62,500.00
Film Society	3,380.00
Sinhala Basha Society	253,500.00
Sinhala Drama Society	52,000.00
Oriental Music Society	70,000.00
Unesco Club	32,500.00

Sinhala Debating Society	367,000.00
Science Society	106,000.00
English Debating Society	35,500.00
Commerce Society	78,000.00
Eve of Acapella	178,000.00
Political Science	19,000.00
	<u>1,272,380.00</u>
<b>Security Deposit Canteen &amp; other Fund</b>	
Donation received during the year for the canteen development	<u>185,000.00</u>

## Funds Movement Analysis Expenses

### Security Fund

Security Expenses	<u>6,684,374.83</u>
-------------------	---------------------

### Building Maintenance Fund

School Maintenance	422,358.28
Building Maintenance Expenses	<u>1,687,163.28</u>
	<u>2,109,521.56</u>

### Sports Fund

		<u>Coaches - Salary</u>
Athletic	171,953.50	
Badminton	324,467.00	479,705.89
Baseball	71,984.00	
Basketball	510,601.98	455,357.13
Boxing	121,140.00	
Bradby	29,813.50	
Cadeting Platoon	184,867.55	
Carrom	71,805.00	84,000.00
Chess	26,400.00	
Cricket	93,975.00	
Drill	6,555.00	
Elle	91,990.00	31,000.00
Gymnastic		142,500.00
Hockey	156,345.00	240,000.00
Karate	46,000.00	265,500.00
Other	3,200.00	
Rugby	52,295.00	
Soccer	38,495.00	204,000.00
Sports Equipment	34,250.00	
Squash		358,125.00
Swimming	635,880.00	719,745.67
Table Tennis	53,450.00	155,000.00
Tennis	20,000.00	240,000.00
Volley Ball	84,185.00	258,285.72
Water Polo	10,250.00	130,000.00
Wushu	6,565.00	97,500.00
	<u>2,846,467.53</u>	<u>3,860,719.41</u>

6,707,186.94

#### Stationery Fund

Other Printing	483,329.08
Stationery Expenses	<u>5,020,440.12</u>
	<u>5,503,769.20</u>

#### Library Fund

Library Expenses	19,168.00
Books	62,353.50
Magazine	42,482.00
News Papers	245,547.60
Software (ISURU)	10,000.00
	<u>379,551.10</u>

#### Technological Studies Fund

Electricity- Technological Expenses	698,570.00
-Computer Section	318,169.50
-Grade 8 IT Lab	468,235.21
-Grade 9 IT Lab	469,303.29
-New Computer Section	<u>515,672.03</u>
	<u>2,469,950.03</u>

#### Sanitary Fund

Sanitary Expenses	<u>1,092,136.88</u>
-------------------	---------------------

#### Electricity Fund

Auditorium	50,590.50
Ground Water Pump	51,337.50
Hostel	371,743.02
J.R.J. Building	266,765.43
Junior Hostel	228,081.50
Main Building	968,002.01
Main Canteen	54,057.88
Main Canteen - New Meter	98,503.35
Nawaragahala	649,272.86
New Hostel	126,257.61
Primary Section	<u>640,302.27</u>
	<u>3,504,913.93</u>

#### Lab Equipment Fund

Lab Equipment Expenses	<u>480,715.00</u>
------------------------	-------------------

#### Club & Societies Fund

Astronomical Society	4,000.00
Interact Club	57,500.00

Art Circle	140,763.60
Sinhala Basha Society	574,669.00
Sinhala Drama Society	74,000.00
Oriental Music Society	348,825.00
Unesco Club	72,250.00
Sinhala Debating Society	50,000.00
Science Society	76,646.00
Commerce Society	78,400.00
Eve of Acapella	230,000.00
Aviation Society	24,500.00
Felicitaton	637,000.00
Other	123,750.00
Scout	56,000.00
	<u>2,548,303.60</u>



Royal College School Development Society  
Cash Flow Statement for the Year Ended 31st December 2010

**Operating Activities**

Excess of Expenditure over Income	(1,211,141)	
<b>Adjustments for:</b>		
Fixed Deposit Interest	(493,241)	
Prior Years Adjustments	<u>499,900</u>	6,659
Changes in Working Capital		
Increase in Inventories	(780)	
Decrease in Advance Payments	74,090	
Increase in Receivables	(340,000)	
Increase in Refundable Deposits	250,000	
Decrease in Creditors	(42,176)	
Decrease in Accruals	<u>(1,399,814)</u>	(1,458,680)
Increase in Other Funds	<u>7,858,844</u>	
<b>Net Cash generated from Operating Activities</b>		<b>5,195,682</b>

**Investing Activities**

Acquisition of Property, Plant & Equipment	(2,367,810)	
	<u>493,241</u>	
Net Cash Used in Investing Activities		(1,874,569)

**Financing Activities**

Net Cash Used in Financing Activities		-
Net Decrease in Cash & Cash Equivalents		<u>3,321,113</u>
Cash & Cash Equivalents at the Beginning of the Year		(2,925,909)
Cash & Cash Equivalents at the End of the Year (Note 4)		<u><u>395,204</u></u>

